

Peripheral targets of centrally located putative accessory neurons of MRO in the isopod *Ligia exotica*

Noriyuki Hama¹, Yoshinori Okada², Edit Pollák³, László Molnár³ and Akiyoshi Niida^{2,*}

¹*Animal Behavior and Intelligence, Division of Biological Sciences, Graduate School of Science, Hokkaido University, Sapporo 060-0810, Japan* ²*Department of Biology, Faculty of Science, Okayama University, Okayama Tsushima 700-8530, Japan* and ³*Department of General Zoology and Neurobiology, University of Pécs and Adaptation Biological Research Group of the Hungarian Academy of Sciences, H-7601 Pécs, Ifjuság útja 6, Hungary*

*Author for correspondence (e-mail: niida@cc.okayama-u.ac.jp)

Accepted 9 April 2003

Summary

The three centrally located putative accessory neurons of the muscle receptor organ (MRO) of the isopod *Ligia exotica* were identified to the third segmental nerve (N3) of the thoracic ganglion by backfilling with Lucifer Yellow. These neurons were then studied intracellularly and extracellularly to determine whether they suppressed the stretch-activated responses of thoracic stretch receptors. Intracellular injection of depolarizing currents into these three putative accessory neurons revealed that only neuron #3 had an inhibitory effect, suggesting that it is an inhibitory accessory neuron related to thoracic stretch

receptors. We searched for the peripheral targets of neurons #1 and #2 by intracellular filling with Lucifer Yellow or by recording of junctional potentials in extensor muscles, and show that they are motor neurons that innervate the deep extensor and superficial extensor muscles, respectively.

Key words: Crustacea, Isopoda, *Ligia exotica*, thoracic stretch receptor, muscle receptor organ (MRO), identified accessory neuron, reflex activation, intracellular labeling, Lucifer Yellow.

Introduction

Muscle receptor organs (MROs) are generally found in both the thorax and abdomen of Malacostracan crustaceans (Alexandrowicz, 1951, 1967; Pilgrim, 1960; Rydqvist, 1992; Macmillan and Field, 1994; Wallis et al., 1995). The abdominal MROs of the decapod crustaceans *Homarus vulgaris* and *Palinurus vulgaris* are innervated by two efferent axons called accessory nerves (thick and thin nerves), and by an X-fiber (Alexandrowicz, 1951). Kuffler and Eyzaguirre (1955) reported the inhibitory action of accessory neurons in crayfish. The reflex inhibitory action of accessory neurons activated by MROs of the same and neighboring segments was then reported (Eckert, 1961; Fields et al., 1967; Jansen et al., 1970a,b, 1971). Based on these studies, Wine and Hagiwara (1977) explored the origin of such accessory neurons in the CNS of the crayfish *Procambarus clarkii*, and in the next-posterior abdominal ganglion found four putative accessory neurons: Acc-1 (accessory-1) to Acc-4. These neurons have not, however, been directly demonstrated to inhibit the stretch-activated response of MRO by intracellular studies combined with dye labeling.

In the isopod *Ligia oceanica*, the presence of the MRO was first described by Alexandrowicz (1967) and its stretch-activated response was recorded by Alexander (1971) only from the rapidly adapting stretch receptor. A subsequent study

on the stretch receptor in *Ligia exotica* reported that MROs with rapidly and slowly adapting stretch receptors were located in the third to the eighth thoracic segments, and also occurred in the reduced abdominal segments (Niida et al., 1995a). The presence of inhibitory accessory neurons in isopods has been reported in *Armadillidium vulgare* (Niida et al., 1991, 1998) and *Bathynomus doederleini* (Niida et al., 1995b; Iwasaki et al., 2001). The location and morphology profiles of the putative accessory neurons of isopods are similar to those in crayfish, being located just below the surface on the dorsal side in the thoracic ganglia, so it is not difficult to impale them with electrodes for intracellular recording. In particular, one of the centrally located neurons in the thoracic ganglion, possibly equivalent to the putative thick accessory neuron of crayfish, is visible under a dissecting microscope. We were thus able to investigate the accessory neurons of *Ligia exotica* intracellularly.

We first examined the putative accessory neurons in the next-caudal ganglion of the thorax by backfilling with Lucifer Yellow to the segmental nerve, as described by Wine and Hagiwara (1977). The inhibitory effects of these neurons were then examined and their morphology identified by intracellular dye marking. Part of the present study has already been reported in abstract form (Hama and Niida, 2000).

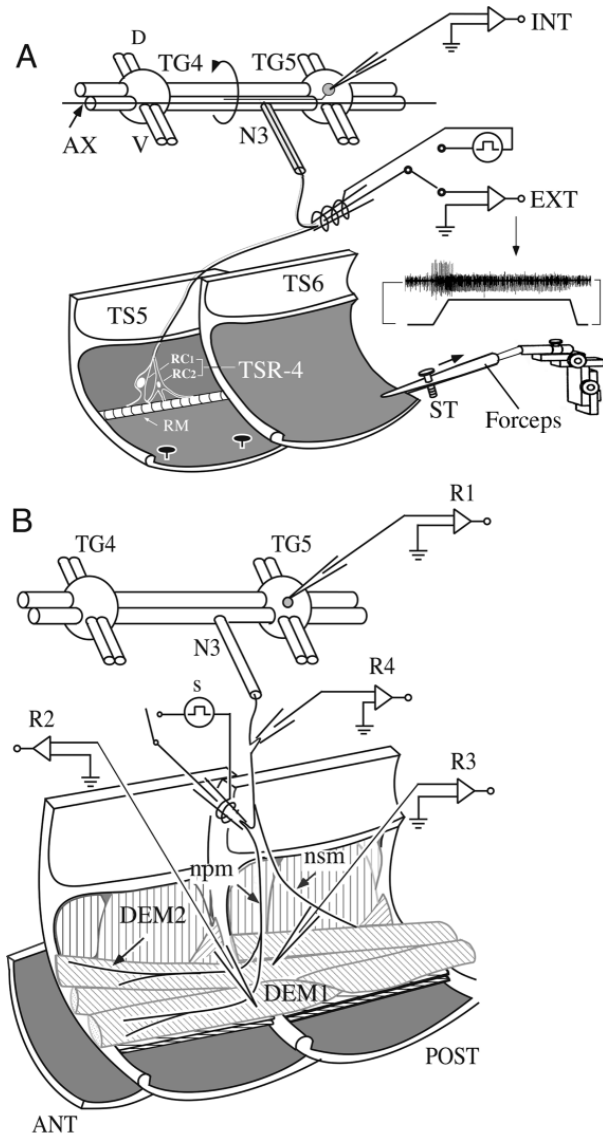

Fig. 1. (A) Setup for ascertaining the inhibitory effect of accessory neurons on stretch-activated responses of TSR. An *en passant* suction electrode is used for antidromic stimulation of accessory neurons and for extracellular recording of stretch-activated responses which, at the same time, show the presence or absence of an inhibitory effect of putative accessory neurons. By pulling the tergite of the sixth thoracic segment, the receptor muscle of TSR-4 is stretched and stretch-activated responses occur as shown (arrow) in a representative trace composed of rapidly and slowly adapting responses. (B) Arrangement of electrodes for recording junctional potentials from two extensor muscles. Experiments were carried out to determine which muscle is innervated by neuron #1. To record junctional potentials of DEM1, the recording (R) and stimulating (S) electrodes were R1, R2, R4 and S. For DEM2, R1, R3, R4 and S were used. Each experiment was conducted in a separate animal. ANT, anterior; AX, axon of the receptor cell of the thoracic stretch receptor; D, dorsal; DEM1, medial deep extensor muscle; DEM2, lateral deep extensor muscle; EXT, extracellular recording; INT, intracellular recording; N3, third segmental nerve; npm, nerve to deep extensor muscle; nsm, nerve to superficial extensor muscle; POST, posterior; RC1, receptor cell of rapidly adapting stretch receptor; RC2, receptor cell of slowly adapting stretch receptor; RM, receptor muscle; ST, stretch stimulus; TG, thoracic ganglion; TS, thoracic segment; TSR, thoracic stretch receptor; V, ventral.

The proximal cut end of the third segmental nerve (N3), equivalent to N2 of the abdominal ganglion in decapods (Iwasaki et al., 2001), was placed on the tip of a polyethylene tube (1.5 mm in diameter) filled with 5% Lucifer Yellow (w/v in aqueous solution), and subjected to 0.5 s pulses of negative current (0.5 μ A) for 1.5 h. Lucifer Yellow-filled preparations were kept for 12 h at 4°C to allow diffusion of the dye, then fixed in 10% formalin for 1 h and cleared in glycerin containing an anti-fade reagent (FluoroGuard; Bio-Rad Laboratories, Hercules, CA, USA).

Preparation for physiological experiments

The inhibitory effect of a putative accessory neuron on the stretch-activated response of a thoracic stretch receptor (TSR) was determined between the fifth thoracic ganglia and the TSRs of the fifth somites (TSR-4s) (Fig. 1A) except for one experiment, which tested between the fourth thoracic ganglion and TSR-3. The fifth thoracic ganglia and TSR-4s are easily accessible for performing electrical stimulation, stretch stimulation, extra- and intracellular recordings. The sternites were removed from the ventral surface of the animal, exposing the thoracic and abdominal ganglia with connectives. The nerve cords and ganglia posterior to the second thoracic ganglion were left intact together with tergites of the fifth and sixth thoracic segments, and all the segmental nerves except N3 of the fourth thoracic ganglion were cut off. Accordingly, the TSR of the fifth somite has a central connection through N3 of the fourth thoracic ganglion (Fig. 1A). To access accessory neurons lying on the dorsal side of the thoracic ganglion, the dorsal side of the ganglia with connectives, with only one N3 segmental nerve as mentioned above, was

Materials and methods

Animals

Specimens of the isopod *Ligia exotica* Roux were collected along the coast of the Seto Inland Sea near Ushimado Marine Laboratory, Faculty of Science, Okayama University, Japan. They were kept at 20°C in a container filled with seawater to a depth of 0.1–0.2 cm, and provided with timber and stones to recreate their habitat. By this simple method we could maintain animals reliably for a long period. Both males and females (overall length 1–3 cm) were used in this study.

Extracellular filling with Lucifer Yellow for identification of accessory neurons

After anesthetizing the animals in cooled *Ligia* physiological saline (Yamagishi and Ebara, 1985), the legs, sternites and viscera were removed. The second and seventh tergites of the thoracic segments were then fixed with small pins on cork lining the bottom of an acrylic plastic chamber.

exposed (Fig. 1A), and fixed with small pins to cork lining the chamber. The chamber was filled with saline and kept at 20°C.

Stretch stimulation

All of the segments except the fifth and sixth thoracic segments were cut off and their hemisegments were left by the bisection of tergites along the midline. The tergum of the fifth thoracic segment was fixed with small pins, and stretch stimuli (ST) were then delivered by manually pulling the free tergite of the sixth thoracic segment with forceps mounted on a micromanipulator (Fig. 1A).

Intra- and extracellular recordings

A neuron impaled with a glass microelectrode and tentatively identified as a putative accessory neuron, based on antidromic stimulation to N3 of the fourth thoracic ganglion, was injected with depolarizing currents (5–10 nA). The inhibitory effect on the stretch-activated response of the thoracic stretch receptor was then ascertained extracellularly in N3 through an *en passant* suction electrode (Fig. 1A). Simultaneously, in order to label the impaled neurons in the CNS, a hyperpolarizing intermittent current (–4 nA; frequency, 1 Hz; duration, 500 ms) was passed through an intracellular electrode filled with Lucifer Yellow for more than 60 min. To ensure diffusion of Lucifer Yellow, these preparations were occasionally stored overnight in a refrigerator (4°C).

Recording of inhibitory synaptic potentials in receptor cells

The stretch-activated response of a rapidly adapting stretch receptor of *Ligia exotica* ceases within a very short period during stretch stimulation. Accordingly, unlike with slowly adapting stretch receptors, it is difficult to examine inhibition of the stretch-activated response by the extracellular recording method above. Instead, we directly recorded inhibitory synaptic potentials from the receptor cells of rapidly adapting stretch receptors by injecting depolarizing currents into the putative accessory neurons in the CNS. Three electrodes were used for this: the first for impaling the rapidly adapting stretch receptor neuron, the second *en passant* at N3 and the third for current injection into neuron #3. Furthermore, to show that hyperpolarizing potentials in receptor cells of stretch receptors were synaptically mediated, the membrane potential of rapidly adapting stretch receptor neurons was changed at three levels by clamping currents. Subsequently, the impaled neurons were labeled with Lucifer Yellow and identified.

Junctional potentials in extensor muscles

When a putative accessory neuron such as neuron #1 failed to inhibit a stretch-activated response, or when we were unable to trace its Lucifer Yellow-filled terminal site, its peripheral target was intracellularly determined as shown in Fig. 1B. The first intracellular electrode (R1) was inserted into neuron #1 in TG5 and the second (R2) and third (R3) electrodes into the DEM1 and DEM2, respectively. Electrical stimulation was made at the nerve to deep extensor muscles (npm) through an *en passant* electrode (S). Recordings from impaled neurons

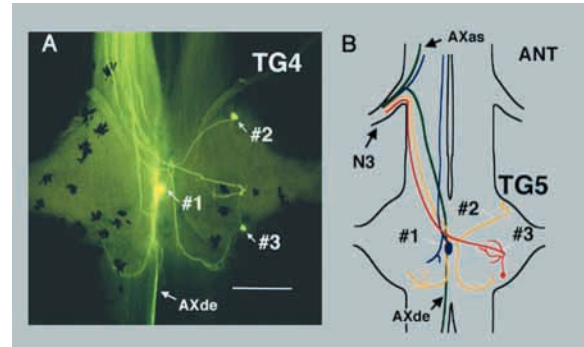

Fig. 2. (A) Lucifer Yellow-filled putative accessory neurons and TSR axon in the fourth thoracic ganglion (TG4). Lucifer Yellow was applied to the cut end of the third segmental nerve of the third thoracic ganglion. Black fragments on the dorsal surface of the thoracic ganglion show melanophores. The dorsal side is up. Bar, 300 μ m. (B) Schematically depicted accessory neurons and TSR axon in TG5 based on backfilling with Lucifer Yellow. ANT, anterior; AXas, ascending axon of the receptor cell of the thoracic stretch receptor; #1–3, putative accessory neurons; TG, thoracic ganglion.

and muscles, or intracellular stimulation were performed using conventional intracellular techniques, with glass microelectrodes filled with either 5% Lucifer Yellow in 1 mol l⁻¹ LiCl (resistance 15–30 M Ω) or 2 mol l⁻¹ potassium citrate (5–10 M Ω).

Results

Extracellular filling

Lucifer Yellow was applied to N3 in 30 specimens, using the third to fifth thoracic ganglia. Motor neurons, unidentified primary afferents, putative accessory neurons and axons of thoracic stretch receptors (TSRs) were labeled. The following description is limited to a given segment, but it also applies to the third to seventh thoracic segments.

The labeling profiles of TSR axons are shown in Fig. 2A,B, where the axon of TSR-4 (also see Fig. 1A) bifurcates near the root of N3 in TG4; one ascends (AXas) while the other descends (AXde). Each axon runs through the central part of the ganglia, medially along the connective and ending in the tritocerebrum or in the fourth abdominal ganglion (not shown), as in *Armadillidium vulgare* (Niida et al., 1998).

Lucifer Yellow-backfilling regularly stained three putative accessory neurons #1, #2 and #3, in order of decreasing cell size, whose location and morphology profiles were consistent in each thoracic ganglion (Fig. 2A,B). The detailed profiles of these putative accessory neurons are described below.

Intracellular identification of putative accessory neurons and their targets

Neuron #1

During a single or repetitive electrical stimulation of N3, a glass microelectrode was impaled on the perikaryon of the supposed neuron #1, producing a small antidromic response

Fig. 3. (A) Profile of intracellularly stained neuron #1. Neuron #1 has a large cell body and gives off dendritic branches in the next-anterior ganglion (double arrows in TG3). Its axon was traced near DEM2. Bar, 300 μ m. Based on this result, Lucifer Yellow was extracellularly applied to the distal cut end of npm (B). As a result, some motor neurons (arrowheads in the next-anterior ganglion, TG3) and neuron #1 are labeled (Bi). The photograph was taken under normal and ultraviolet light. (Bii) is rotated by 90° relative to (Bi). Bar, 500 μ m. N1/N2, first and second segmental nerve; N3, third segmental nerve; npm, nerve to deep extensor muscles; SR, stretch receptor; TG, thoracic ganglion.

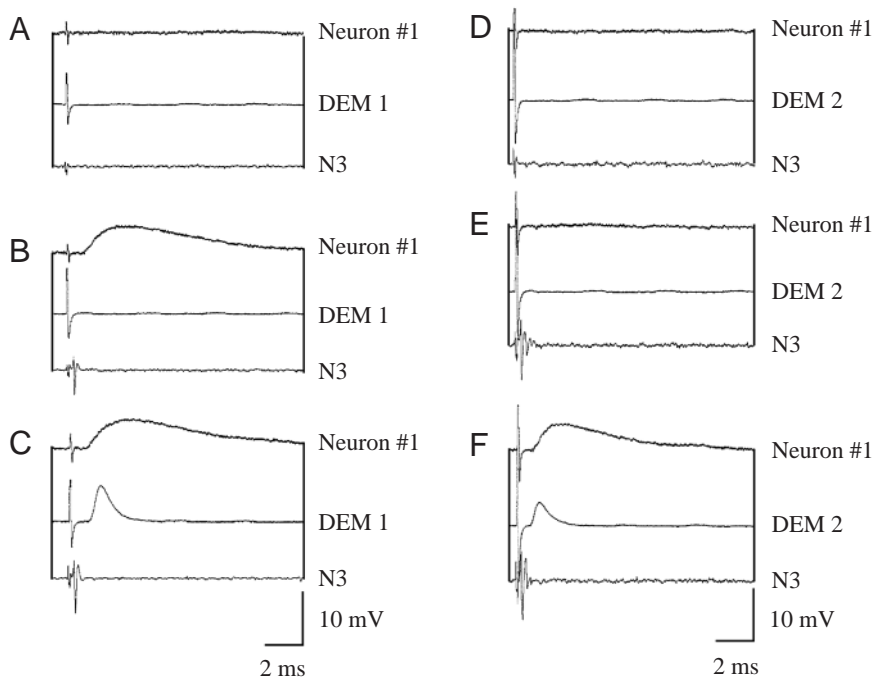
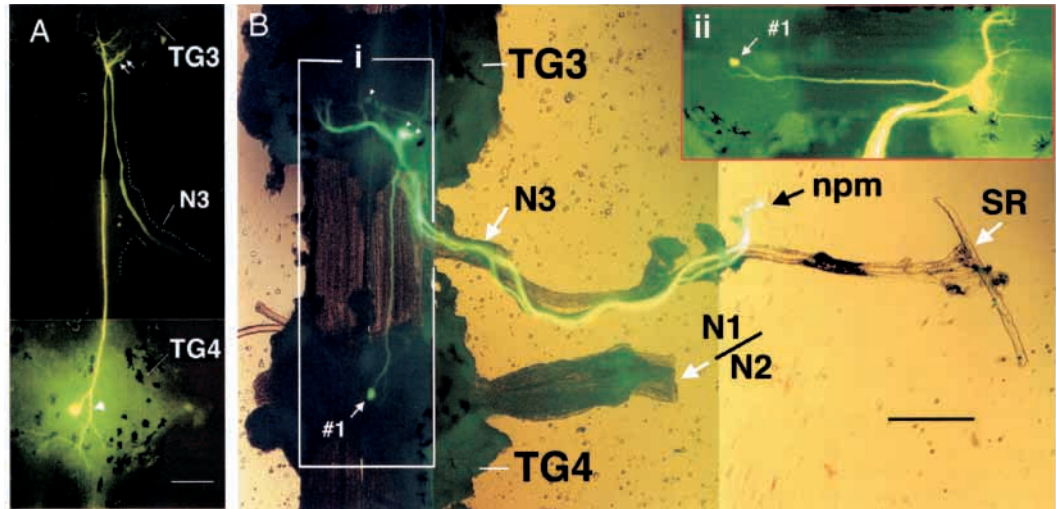

Fig. 4. Excitatory junctional potentials of DEM1 and DEM2 following electrical stimulation of nerve to deep extensor muscles (npm). Stimulation was gradually increased from A to C and from D to F. Two experiments (A–C and D–F) were performed in separate animals. (A–C) Recordings were taken simultaneously from neuron #1, DEM1 and N3. Junctional potentials in DEM1 (middle trace in B) were not obtained at a stimulus intensity that activated neuron #1, while a greater stimulus produced an excitatory junctional potential (middle trace in C). (D–F) Recordings were taken simultaneously from neuron #1, DEM2 and N3. A given stimulus intensity caused compound action potentials in N3 (bottom trace in E), but neither neuron #1 nor DEM2 are activated. However, a stimulus intensity that activates neuron #1 (top trace in F) brings about a junctional potential in DEM2 (middle trace in F).

with a resting membrane potential of 40–60 mV (not systematically studied). Immediately thereafter, depolarizing currents (4–10 nA) were passed into the impaled neuron, but we never found spike initiation in itself, and an ongoing stretch-activated response, monitored through an *en passant* suction electrode, was not inhibited at all. Six such neurons were intracellularly studied and stained with Lucifer Yellow. All the Lucifer Yellow-filled neurons displayed the morphology shown in Fig. 3A, and the profile matched neuron #1 (Fig. 2B). The cell body (approximately 60 μ m) is located in the central area of TG4, and gives off a short neurite that bifurcates anteriorly and posteriorly. The posterior short

branch further divides into two branches (arrows in Fig. 3A). The anterior neurite, of large diameter, runs through the connective, reaching the caudal region of the next-anterior ganglion (TG3), and issues numerous branches in the area where the extensor and flexor motor neurons of TG3 lie. The neurite then sharply curves, descends the connective and enters N3. Its subsequent pathway was traced near the deep extensor muscle (DEM), but we could not follow it any further due to weak Lucifer Yellow-labeling. Based on this, we applied backfilling with Lucifer Yellow to the more proximal cut end of the nerve (npm) innervating the deep extensor muscle, and this labeled neuron #1 in TG4 and motor neurons in TG3 (small

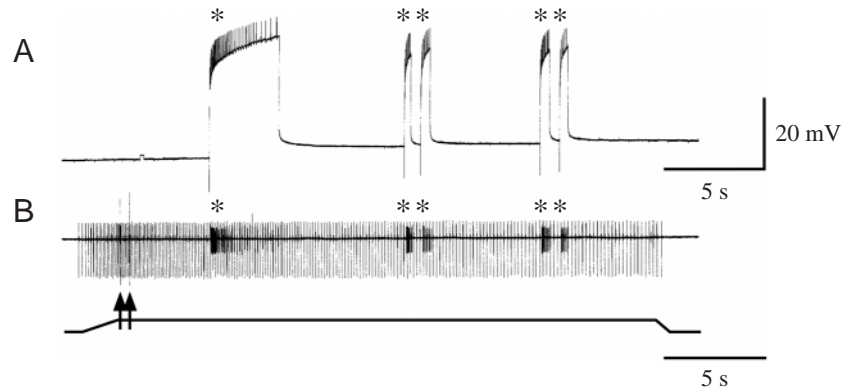

Fig. 5. Lack of effect of neuron #2 on the stretch-activated response. (A) Injection of depolarizing currents into neuron #2 produced regenerative action potentials (asterisks). (B) Such activation of neuron #2 had no effect on the stretch-activated response of TSR-4, where single and double asterisks indicate impulses conducted along the connective from depolarized neuron #2. If neuron #2 was an inhibitory accessory neuron, the stretch-activated response in B would be suppressed. Both the conducted impulses and the stretch-activated response were recorded through an *en passant* electrode at N3. Double arrows indicate stretch-activated impulses of TSR-4 derived from a rapidly adapting stretch receptor. The upward deflection below the trace shows a stretch stimulus at an amplitude of 1.5 mm.

arrowheads in Fig. 3Bi). We concluded that neuron #1 is not an inhibitory accessory neuron, but rather a motor neuron of DEM. The deep extensor muscle consists of the medial deep extensor muscle (DEM1) and lateral deep extensor muscle (DEM2) (Fig. 1B, and also see Fig. 7). To determine which muscle is innervated by neuron #1, we recorded junctional potentials from DEM1 and DEM2 in separate animals (ten specimens in total, five of each), as shown in Fig. 1B. When the npm was weakly (2 V) electrically stimulated, no responses were seen in neuron #1, DEM1 or N3 (Fig. 4A). A more intense electrical stimulus was then delivered, which resulted in both an antidromic response in neuron #1 and compound action potentials at N3 (Fig. 4B), but there was still no response in DEM1. Electrical stimulation at an even higher intensity (3 V) finally recruited a junctional potential in DEM1 (Fig. 4C). Similarly, junctional potentials of DEM2 were then recorded in a separate specimen. Electrical stimulation at a low intensity (3 V) was made at the npm, with no response (Fig. 4D). A slightly more intense stimulus produced only compound action potentials at N3. An even more intense stimulus was then delivered at the npm, and produced a junctional potential in DEM2, an antidromic response in neuron #1, and compound action potentials. If neuron #1 sends its axon to DEM2, the simultaneous occurrence of an antidromic response in neuron #1 and a junctional potential in DEM2 with electrical stimulation at a given intensity would indicate that they have similar excitation thresholds (Fig. 4E). In contrast, an antidromic response in neuron #1 and a junctional potential in DEM1 are evoked by electrical stimulation of their axons with different thresholds (Fig. 4B,C). This indicates that DEM1 is not innervated by neuron #1, but rather by motor neurons in the next-anterior ganglion (TG3).

Neuron #2

Following electrical stimulation of N3 in the fourth thoracic ganglion, an antidromic response of shorter duration than that of neuron #1 was intracellularly recorded from the neuron in the central area of the fifth thoracic ganglion. This shorter duration of the antidromic response was useful as a landmark to

distinguish neurons #2 and #3 from neuron #1. When TSR-4 was activated by stretch stimuli, its response was recorded from N3 through an *en passant* suction electrode (Fig. 1A). Approx. 5 s after beginning stretch stimulation, depolarizing currents were intracellularly passed from the impaled neurons. The impaled neurons then initiated impulse discharges (Fig. 5A); they conducted along the connective anterior to the fifth thoracic ganglion and appeared in N3 as small impulses (single and double asterisks in Fig. 5B). However, there was no effect on the stretch-activated response of TSR-4. A hyperpolarizing current was then injected into the impaled neuron for Lucifer Yellow staining (profile shown in Fig. 6), which was identified as neuron #2 in Fig. 2B. The cell body of approximately 30 μm lies in the anterior hemiganglion contralateral to the side where the axon exits at N3 (Fig. 6A). The neurite from the cell body goes down obliquely and forms a deformed Ω -like dendritic structure in the central area of the fifth thoracic ganglion. The neurite issuing from the Ω -like structure then goes upward and bifurcates near the root of N3. One branch reaches the posterior region of the fourth thoracic ganglion and gives off small dendritic branches (double arrows in Fig. 6A). The other runs toward the periphery *via* N3; it courses npm and terminates in the superficial extensor muscle (SEM1 and SEM2) within the area-1 in Fig. 6, shown enlarged in area-2, in which the Lucifer Yellow-filling nerve toward the SEM1 and SEM2 passes through the stretch receptor without giving off axon branches. The spatial arrangement of the superficial extensor muscle and thoracic stretch receptors is shown in Fig. 7. The example in Fig. 6A thus enabled us to determine its destination by overnight diffusion of Lucifer Yellow. The staining quality was insufficient due to movement of the dye, but another sample provided a detailed profile of neuron #2 with the Ω -like dendritic structure (Fig. 6B). Seven samples were thus stained intracellularly. They showed almost the same morphological characteristics and had no inhibitory effect on the stretch-activated response.

Neuron #3

Inhibitory innervation of slowly adapting stretch receptor

The response of impaled neurons to antidromic stimulation at N3 was ascertained, and a stretch stimulus was then

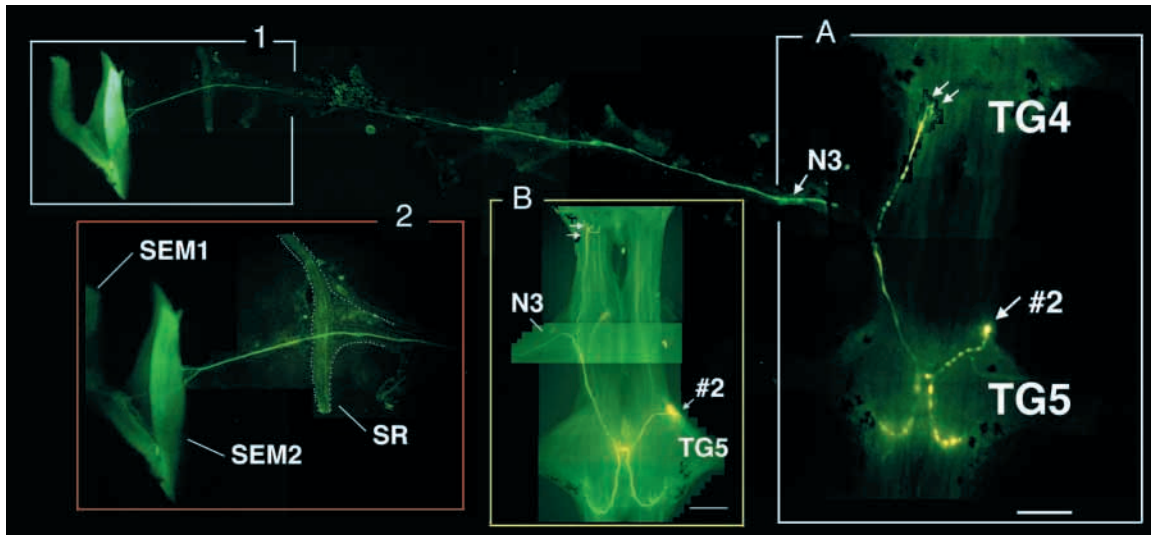

Fig. 6. Profile of intracellularly stained neuron #2. (A) The impaled neuron with the response properties shown in Fig. 5 was intracellularly labeled with Lucifer Yellow. The axon of neuron #2 labeled with Lucifer Yellow was directly traced to the superficial extensor muscle (Area-1), shown enlarged in Area-2. Note that there are no axonal branches to share with the stretch receptor. (B) The complete profile of another neuron #2 with a deformed Ω -like dendritic structure. Bars, 500 μ m. N3, third segmental nerve; SEM1, medial superficial extensor muscle; SEM2, lateral superficial extensor muscle; SR, stretch receptor; TG, thoracic ganglion.

delivered to TSR-4 (see Fig. 1A). The response of stretch-activated TSR-4 was extracellularly recorded from N3 through an *en passant* electrode (Fig. 8A). At the beginning of stretch stimulation, indicated as an upward deflection in the lower trace in Fig. 8A, rapidly adapting large impulse discharges (arrows) occurred together with slowly adapting impulse discharges, which were maintained during stretch stimulation.

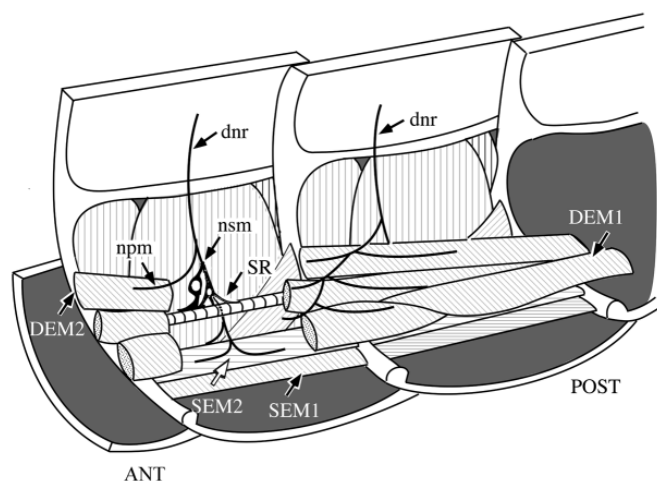

Fig. 7. Spatial arrangement of the superficial extensor muscle, the deep extensor muscle and the stretch receptor. They are depicted on one side bisected along the midline. The dorsal nerve (dnr) continues to the third segmental nerve. A pair of thoracic stretch receptors is located under the lateral deep extensor muscle (DEM2). The superficial extensor muscles (SEM1 and SEM2) lie under the medial deep extensor muscle (DEM1). ANT, anterior; npm, nerve to deep extensor muscles; nsm, nerve to superficial extensor muscle; POST, posterior; SR, stretch receptor.

Concomitantly with the stretch-activation of TSR-4, the impaled neuron produced a few sporadic impulses and a series of EPSPs (Fig. 8B,C); the two parts of the trace in rectangles in Fig. 8Bi,ii were enlarged, and show stretch-activated EPSPs in Fig. 8Ci,ii. This indicates that there is synaptic contact between TSR-4 and the impaled neurons. Therefore, depolarizing currents were passed into the impaled neuron (asterisks in Fig. 8B), which produced regenerative impulses in its own cell. Simultaneously, the preceding stretch-activated response of TSR-4 with slowly adapting impulse discharges was apparently suppressed (asterisks in Fig. 8A) along with the presence of small impulses at a high frequency in the part indicated by the asterisks. After completing the physiological experiments, the impaled neurons ($N=6$) were stained intracellularly with Lucifer Yellow to reveal the morphology of neuron #3 (Fig. 2B). As seen in Fig. 9, a cell body (about 20 μ m) lies in the fifth posterior hemiganglion. The neurite from the cell body gives off dendritic branches, turns sharply to the left and forms an H-like dendritic structure in the central area of the thoracic ganglion. The neurite courses obliquely, reaches the root of N3 and descends to the periphery. We were unable to trace its axon to the stretch receptor, however, due to weak Lucifer Yellow-filling.

Synaptic sites of TSR axon on neuron #3

To find the possible synaptic sites of the axon of TSR on neuron #3, we tried intracellular recording from neuron #3 in TG-5 and TSR axons passing through TG-5 along with their intracellular labelings. As a result, the descending axon (Axde) of TSR-4 (Fig. 10A) completely overlapped one component of the H-like dendritic structure of neuron #3 in TG-5 (thin arrow in Fig. 10A). If the TSR axon *via* N3 on the opposite side was

Fig. 8. Inhibition of stretch-activated responses of the thoracic stretch receptor by a putative accessory neuron. (A) In accordance with the injection of depolarizing currents into the putative accessory neuron (asterisks in B), the stretch-activated response was suppressed (asterisks in A). Each arrow in trace A shows rapidly adapting impulses caused by a jerky stretch stimulus delivered manually, which appears as inflection points on the monitor trace below trace A. Paired arrows on the right hand side of the trace A indicate the impulse size of slowly adapting stretch receptor. (B) Electrical activities from the putative accessory neuron. Depolarizing current was injected into the putative accessory neuron, resulting in regenerative action potentials (asterisks). (C) Enlargement of the parts enclosed by rectangles (i) and (ii) in A. Stretch-activated EPSPs occur while the stretch stimulus is applied (i and ii) and disappear upon termination of the stretch stimulus. Summation of EPSPs (Ci) produces an action potential, which is shown in smaller amplitude than it really is (Bi). Upward deflections in monitor traces below traces A, B and C show stretch stimuli (amplitude 0.5 mm).

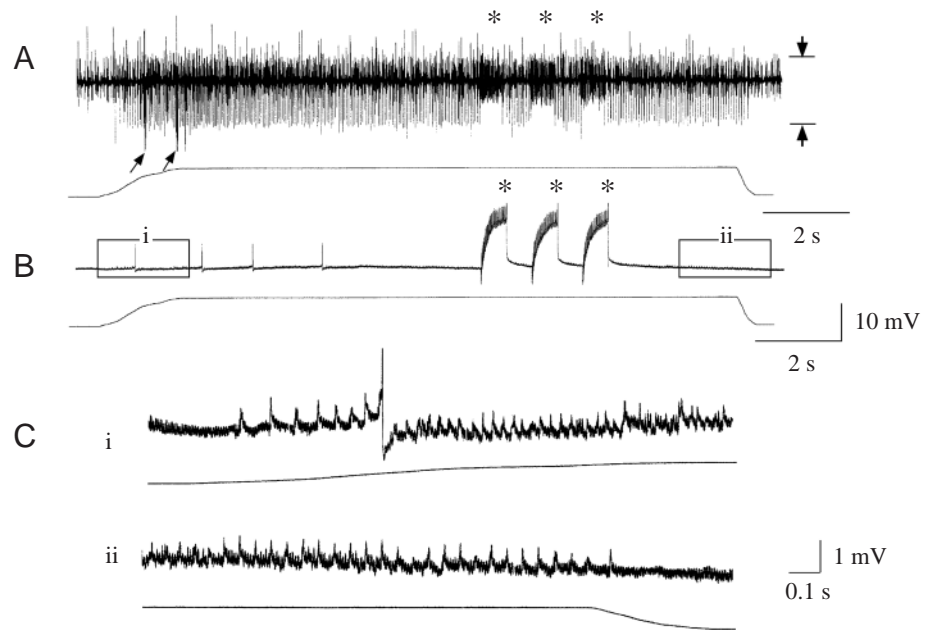

intracellularly labeled, the other component of the H-like dendritic structure (arrowhead in Fig. 10A) would also be overlapped by the descending TSR axon. This presumption is shown in another example (Fig. 10B), where the distal component (to the cell body of neuron #3) of the H-like dendritic structure was overlapped by the contralateral (to the cell body of neuron #3) descending TSR axon *via* N3 in TG3.

Inhibitory innervation of rapidly adapting stretch receptor

We examined whether rapidly adapting stretch receptors (RC1

in Fig. 1A) are innervated by neuron #3 (Fig. 11). A receptor cell (RC1) was penetrated with a glass microelectrode filled with potassium citrate and depolarizing currents were then injected into neuron #3 (Fig. 11A). Since the resistance of the intracellular electrode became too high, the bridge was unbalanced and could not be compensated. The effect of the depolarizing currents was manifested as impulse discharges through the *en passant* electrode at N3 (asterisks in Fig. 11A) and hyperpolarizing potentials were produced in the rapidly adapting stretch receptor neuron (RC1 in Fig. 11A). This potential is considered to be synaptically mediated, since the amplitude of the hyperpolarizing potential changed with the injection of hyperpolarizing or depolarizing currents into the stretch receptor neuron (Fig. 11B).

Discussion

Comparison of neurons #1, #2 and #3 in isopods with accessory neurons in decapods

We assumed that putative accessory neurons in *L. exotica* are morphologically similar to some accessory neurons in crayfish (Wine and Hagiwara, 1977). To support this assumption, the locations and morphology of neurons #1–3 in *L. exotica* were compared to Acc-1 through Acc-4, which have been identified in decapods. The somata of both neuron #1 and

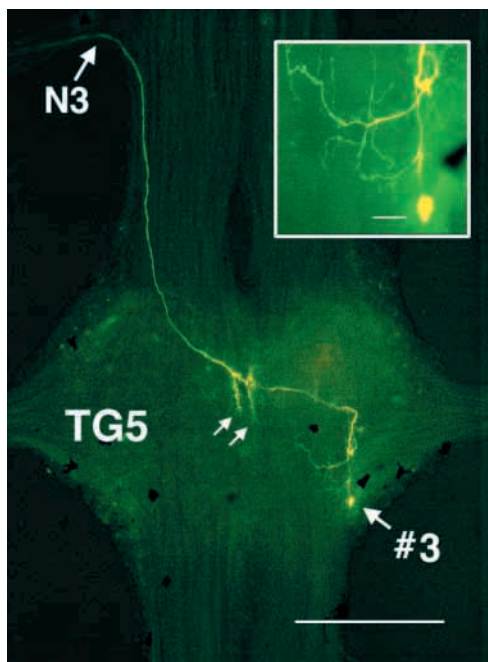
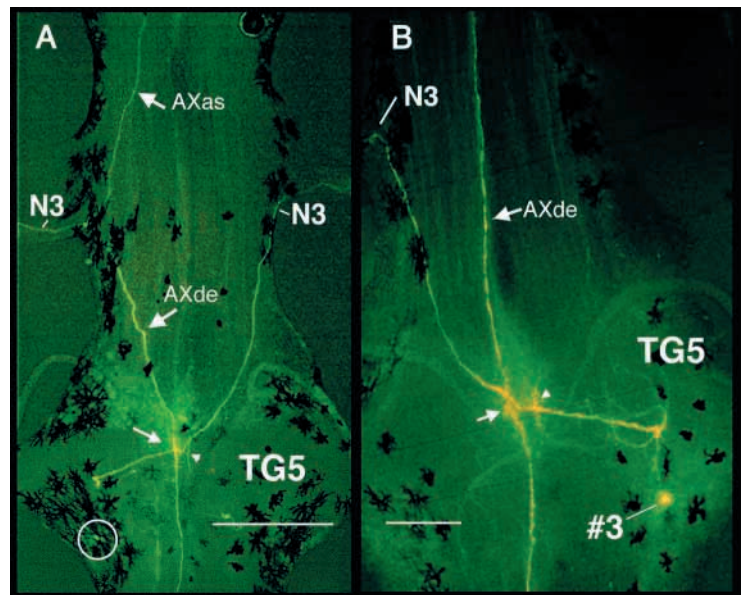

Fig. 9. An example of an intracellularly stained inhibitory accessory neuron. This neuron showed the physiological properties given in Fig. 8 and was identified as a neuron #3, based on its profile. Parallel short vertical dendritic branches at the center of the ganglion (double arrows) are noted. This was revealed by intracellular staining of neuron #3. Bar, 500 μ m. The inset is an enlarged view of neuron #3 at the bottom. Bar, 40 μ m.

Fig. 10. Stretch receptor axons overlapping on the vertical dendritic branches of neuron #3. (A) The axon of TSR-4 (Fig. 1A) reaches the root of N3 belonging to TG4, and bifurcates into ascending and descending axons in the connective. The descending axon overlaps on one vertical dendritic branch of neuron #3 in TG5 (thin arrow). The opposite arrowhead indicates another vertical dendritic branch of neuron #3. The circle shows the location of a neuron #3 covered with melanophores. Bar, 500 μ m. (B) Another example in which the descending stretch receptor axon overlaps on the vertical dendritic branch of neuron #3 (thin arrow) opposite that in A. In this case, the TSR axon was descending at the root of N3 in TG3. The arrowhead indicates another vertical dendritic branch of neuron #3. Bar, 300 μ m. AXas, ascending axon of TSR; AXde, descending axon of TSR; N3, third segmental nerve; TG, thoracic ganglion.



Acc-1, the largest of their respective groups, usually lie near the center of the ganglion, and neuron #1 gives off small dendritic branches latero-posteriorly (arrowhead in Fig. 3A). Such branches can also be seen in Acc-1 of crayfish (fig. 21a in Leise et al., 1987) and in the accessory neuron of a squat lobster (figs 3 and 4 in Wallis et al., 1995). 'As a surprising feature', Wine and Hagiwara (1977) noted that Acc-1 in crayfish had major branches in the next-anterior ganglion. This

structure can also be clearly seen in the intracellularly stained neuron #1 of *L. exotica* (double arrows in Fig. 3A). Neuron #2 and accessory-2 also have similar positional and morphological characteristics; each soma is located contralaterally in the anterior hemiganglion, and neuron #2 has an Ω -like dendritic structure in the center of the ganglion (Fig. 6A,B), while this structure is deformed and deviates laterally from the center of ganglion in Acc-2 of the crayfish, (fig. 10 in Wine and Hagiwara, 1977). Neuron #3 and Acc-4, which are both small, are located contralaterally in the caudo-lateral quadrant. Their courses toward the periphery are similar: the axon from each soma turns sharply and goes up obliquely. The accessory neuron corresponding to Acc-3 in crayfish is consistently lacking in this animal. This was the same in isopods such as *Armadillidium vulgare* (Niida et al., 1998), *Bathynomus doederleini* (A. Niida and A. Namba, unpublished data) and *Idotea balthica*, in which all the neurons highly similar to neurons #1–3 were considered to be motoneurons (Kutsch and Heckmann, 1995).

Reconsideration of putative accessory neurons in isopods and decapods

At the early stages of this experiment, we tentatively regarded neurons #1–3 as putative accessory neurons, based

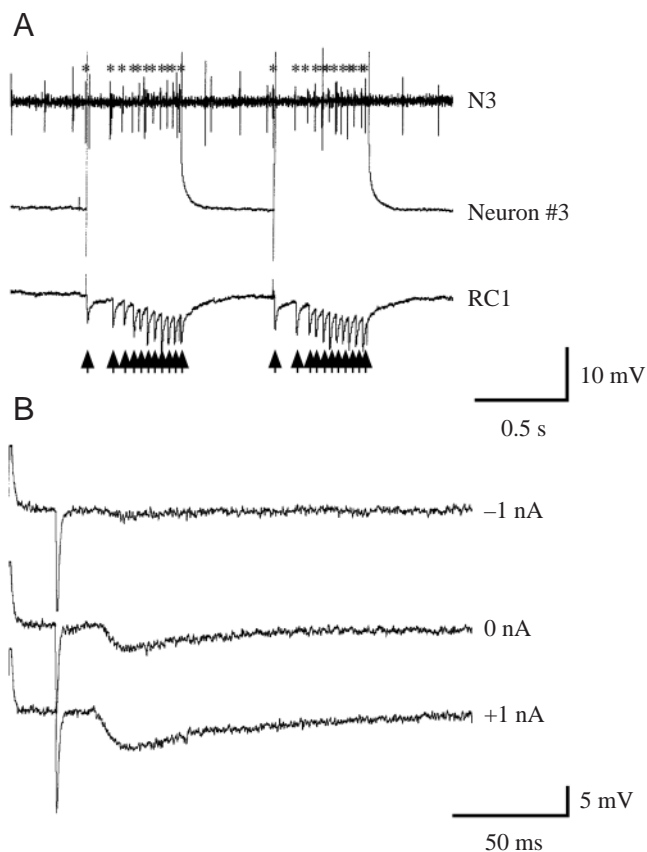

Fig. 11. Inhibitory synaptic input from neuron #3 to the receptor cell of the stretch receptor. (A) Depolarizing currents applied to neuron #3 (middle trace) produce IPSPs in the rapidly adapting stretch receptor cell (RC1 in Fig. 1A) (bottom trace). Impulses of N3 (asterisks) that occurred with the application of depolarizing currents to neuron #3 and were conducted on the connective show one to one correspondence with hyperpolarizing potentials in a receptor cell (RC1) (arrowheads). (B) Demonstration of synaptic input to RC1. The amplitude of hyperpolarizing potential of RC1 mediated by the injection of current to neuron #3 changed depending on the magnitude of current injected into to RC1.

on the results of Wine and Hagiwara (1977). Our intracellular experiments combined with Lucifer Yellow-labeling demonstrated, however, that neurons #1 and #2 are actually motor neurons, and only neuron #3 is an inhibitory accessory neuron. Neuron #1 is morphologically equivalent to Acc-1, which has been considered to be a thick accessory neuron with inhibitory action. Leise et al. (1987) proposed that in the crayfish *Pacifastacus leniusculus* 'Acc-1 might be a common inhibitor, inhibiting the fast extensor muscle as well as MRO, since backfillings from npm routinely stained them'. When Acc-1 is an inhibitory accessory neuron, we expect it is an authentic GABA-ergic neuron based on studies to date (for example, Elekes and Florey, 1987). Such GABA-ergic neurons were immunocytochemically studied in the CNS of the crayfish (Mulloney and Hall, 1990), and there were at most four neurons showing GABA-like immunoreactivity (GLI) as accessory neurons in one abdominal ganglion. In addition, no relationship between thick or thin accessory neurons and neurons with GLI was mentioned. In an immunocytochemical study in isopods, GABA-antibody did not label neuron #1. Instead, neuron #1 was labeled with a tyrosine hydroxylase antibody (Tsumura et al., 2000). Similar results were also obtained in the isopod *Armadillidium vulgare* (Pollák et al., 1999). Accordingly, we suspect that Acc-1 is GABA-ergic.

Reflex input of accessory neurons in the isopod L. exotica

As shown in Fig. 8, neuron #3 receives synaptic input from the thoracic stretch receptor; however, the post-synaptic response of neuron #3 (Fig. 8B,C) to a stretch stimulus seems to be weak, since its stretch-activated impulses are sporadic. Such a weak synaptically mediated response might be due to the recording site, but in this case recordings were made in the vicinity of the H-like dendritic structure of neuron #3 at the central region of TG5 (arrows in Fig. 9). In the present experiment, the amplitude of the stretch stimulus was not large enough to induce noticeable impulse discharges of the rapidly adapting stretch receptor (arrows in Fig. 8A; see the stretch-activated response in Fig. 1A). Accordingly, this weak synaptic activity may be partly related to the strength of stretch stimulation. In addition, we note the reported synaptic efficiency of ipsilateral and contralateral inputs to accessory neurons of crayfish (Jansen et al., 1970a,b). Considering these synaptic inputs, we assume that the convergence of at least two sensory inputs may be required for the initiation of impulse discharges in neuron #3; i.e. the input from stretch receptors on the right and left sides of the same segment or from two successive segments. This interpretation may be supported by the unique neural structure of neuron #3; in the central region of the thoracic ganglion, there are two parallel vertical dendrites of neuron #3, with which the axons of the stretch receptor on each side may make synaptic contact. These assumptions are further supported by the circumstantial evidence shown in Fig. 10. Thus, neuron #3 may be fully activated when it receives simultaneous synaptic inputs from the two vertical dendrites. This could be ascertained in future

by a detailed study of the relationship between reflex inputs and outputs in a given segment or adjacent segments.

This work was supported in part by a grant from the Hungarian National Research Fund (OTCA T026652) to L. Molnár. We thank M. Tsumura for assisting with Lucifer Yellow backfilling and drawings.

References

- Alexander, C. G. (1971). Observation on receptor mechanisms in *Ligia oceanica* (Linn.). *Comp. Biochem. Physiol.* **40A**, 339-347.
- Alexandrowicz, J. S. (1951). Muscle receptor organs in the abdomen of *Homarus vulgaris* and *Palinurus vulgaris*. *Q. J. Microsc. Sci.* **92**, 163-199.
- Alexandrowicz, J. S. (1967). Receptor organs in thoracic and abdominal muscles of Crustacea. *Biol. Rev.* **42**, 288-326.
- Eckert, R. O. (1961). Reflex relationships of the abdominal stretch receptors of the crayfish. I. Feedback inhibition of the receptors. *J. Cell. Comp. Physiol.* **57**, 149-162.
- Elekes, K. and Florey, E. (1987). Immunocytochemical evidence for the GABAergic innervation of the stretch receptor neurons in crayfish. *Neurosci.* **22**, 1111-1122.
- Fields, H. L., Evoy, W. H. and Kennedy, D. (1967). Reflex role played by efferent control of an invertebrate stretch receptor. *J. Neurophysiol.* **30**, 859-874.
- Hama, N. and Niida, A. (2000). Identification of the centrally located accessory neuron associated with the thoracic stretch receptor of the isopod, *Ligia exotica*. *Zool. Sci. Suppl.* **17**, 103pp.
- Iwasaki, M., Ohata, A., Okada, Y., Sekiguchi, H. and Niida, A. (2001). Functional organisation of anterior thoracic stretch receptors in the deep-sea isopod *Bathynomus doederleini*: behavioural, morphological and physiological studies. *J. Exp. Biol.* **204**, 3411-3423.
- Jansen, J. K. S., Njå, A. and Walløe, L. (1970a). Inhibitory control of the abdominal stretch receptors of the crayfish. I. The existence of a double inhibitory feed back. *Acta. Physiol. Scand.* **80**, 420-425.
- Jansen, J. K. S., Njå, A. and Walløe, L. (1970b). Inhibitory control of the abdominal stretch receptors of the crayfish. II. Reflex input, segmental distribution, and output relations. *Acta. Physiol. Scand.* **80**, 443-449.
- Jansen, J. K. S., Njå, A., Ormstad, K. and Walløe, L. (1971). On the innervation of the slowly adapting stretch receptor of crayfish's abdomen. An electrophysiological approach. *Acta. Physiol. Scand.* **81**, 273-285.
- Kuffler, S. W. and Eyzaguirre, C. (1955). Synaptic inhibition in an isolated nerve cell. *J. Gen. Physiol.* **39**, 155-184.
- Kutsch, W. and Heckmann, R. (1995). Homologous structures, exemplified by motoneurons of Mandibulata. In *The Nervous Systems of Invertebrates: An Evolutionary and Comparative Approach* (ed. O. Breidbach and W. Kutsch), pp. 1-6. Basel, Boston, Berlin: Birkhäuser.
- Leise, E. M., Hall, W. M. and Mulloney, B. (1987). Functional organization of crayfish abdominal ganglia. I. Sensory afferents and extensor motor neurons. *J. Comp. Physiol.* **266**, 495-518.
- Macmillan, D. L. and Field, L. H. (1994). Morphology, physiology and homology of the N-cell and muscle receptor organs in the thorax of the crayfish, *Cherax destructor*. *J. Comp. Neurol.* **350**, 573-586.
- Mulloney, B. and Hall, W. M. (1990). GABA-ergic neurons in the crayfish nervous system: An immunocytochemical census of the segmental ganglia and stomatogastric system. *J. Comp. Neurol.* **291**, 383-394.
- Niida, A., Sadakane, K. and Yamaguchi, T. (1991). Abdominal stretch receptor organs of *Armadillidium vulgare* (Crustacea, Isopoda). *Zool. Sci.* **8**, 187-191.
- Niida, A., Takatsuki, Y. and Yamaguchi, T. (1995a). Morphology and physiology of the thoracic and abdominal stretch receptors of the isopod crustacean *Ligia exotica*. *Biol. Bull.* **189**, 148-158.
- Niida, A., Iwasaki, M. and Yamaguchi, T. (1995b). An evolved stretch receptor of the most anterior thoracic segment in the deep-sea Isopoda, *Bathynomus doederleini*. *Physiol. Zool.* **68**, 52.
- Niida, A., Iwasaki, M. and Yamaguchi, T. (1998). Anterior thoracic stretch receptors in a terrestrial isopod (*Armadillidium vulgare*). *Isr. J. Zool.* **44**, 487-500.
- Pilgrim, R. L. C. (1960). Muscle receptor organs in some decapod Crustacea. *Comp. Biochem. Physiol.* **1**, 248-257.
- Pollák, E., Molnár, L. and Niida, A. (1999). Characterization of the

- accessory neurons of stretch receptors in *Armadillidium vulgare* by means of immunocytochemical methods. In *Proceedings of the 6th Annual Meeting of Hungarian Neuroscience Society, Harkány. Neurobiol.* **7**, 376.
- Rydqvist, B.** (1992). Muscle mechanoreceptors in invertebrates. In *Advances in Comparative and Environmental Physiology*, Vol. 10. *Comparative Aspects of Mechanoreceptor Systems* (ed. F. Ito), pp. 233-260. Berlin: Springer-Verlag.
- Tsumura, M., Hama, N., Okada, Y. and Niida, A.** (2000). Immunocytochemical studies of the accessory neuron associated with thoracic stretch receptors of *Ligia exotica*. *Zool. Sci. Suppl.* **17**, 103pp.
- Wallis, E. J., Paul, D. H., Antonsen, B. L. and Hollenberg, R.** (1995). Variations on a segmental theme: Muscle receptor organs and extensor neuromusculature in the squat lobster *Munida Quadrispina* (Anomura: galatheidae). *J. Exp. Biol.* **198**, 2453-2463.
- Wine, J. J. and Hagiwara, G.** (1977). Crayfish escape behavior. I. The structure of efferent and afferent neurons involved in abdominal extension. *J. Comp. Physiol.* **121**, 145-172.
- Yamagishi, H. and Ebara, A.** (1985). Spontaneous activity and pacemaker property of neurons in the cardiac ganglion of an isopod crustacean, *Ligia exotica*. *Comp. Biochem. Physiol.* **81A**, 55-62.