



Monsoon-influenced speciation patterns in a species flock of *Eophreaticus* Nicholls (Isopoda; Crustacea)

George D.F. Wilson^{a,*}, Christopher L. Humphrey^b, Donald J. Colgan^a, Karen-Ann Gray^a, Rebecca N. Johnson^a

^a Australian Museum, 6 College Street, NSW 2010, Australia

^b Environmental Research Institute of Supervising Scientist (eriss), P.O. Box 461, Darwin, NT 0801, Australia

ARTICLE INFO

Article history:

Received 25 August 2008

Revised 3 February 2009

Accepted 7 February 2009

Available online 20 February 2009

Keywords:

Crustacea

Eophreaticus

mtDNA

Speciation

16S rRNA

COI

Kakadu

Arnhem Plateau

Australia

Bar code problems

ABSTRACT

A species flock of the freshwater isopod genus *Eophreaticus* Nicholls lives in seeps, springs and perched aquifers at the base of the Arnhem Plateau and associated sandstone outliers in Australia's Northern Territory. These species have been found to have surprisingly high levels of genetic divergence and narrow range endemism, despite potential opportunities for dispersion during the summer monsoon season when streams flow continuously and have connectivity. Species of *Eophreaticus* were identified morphologically as distinct taxa, sometimes with two or three species occurring at the same site. DNA sequence data from the mitochondrial 16S rRNA and cytochrome *c* oxidase subunit I genes corroborate our morphological concepts to a high level of resolution, with the exception of two distinct species that are identical genetically. The value of mtDNA data for identification of these species, therefore, is limited. These isopods disperse downstream from their home springs to a limited extent during the wet season, but the genetic data show that migration to non-natal springs, and reproduction there, may be rare. We argue that the multiplication of the narrow-range endemic species is the result of their homing behaviour combined with monsoonal alternation between aridity and flooding over recent and geological time scales since the Miocene period.

Crown Copyright © 2009 Published by Elsevier Inc. All rights reserved.

1. Introduction

Eophreaticus Nicholls is a currently monotypic genus of isopod crustaceans, the sole described species being *E. kershawi* from the King River region of northwestern Arnhem Land, Australia (Nicholls, 1926). During the last decade, studies by two of us (GW, CLH: unpublished) have discovered much additional morphological diversity in *Eophreaticus*. These new undescribed species occur in upland seeps, springs, streams or sub-surface (perched aquifer) waters associated with the ancient and weathered sandstone plateau, escarpments and outliers of western Arnhem Land that extend into Kakadu National Park (Fig. 1). These include, to date, sites in the East Alligator, South Alligator, Katherine and Liverpool River catchments. This diversity heralds the existence of many previously unrecognised, and morphologically distinct, species in the genus. Numerous distinctive morphotypes with narrow ranges (on the scale of only a few kilometres) were identified among the collections. Eleven distinct species are shown in Fig. 2, including

several that co-occur (spp. Ga & Gb, 08 & 09) or nearly so (M1 & M2).

These new isopod species are extremely narrow range endemics in a region where the opportunity for dispersal is potentially high during the monsoonal wet season. This result contrasts with the results from ongoing studies of freshwater invertebrates in Kakadu National Park that show an absence of narrow range endemism away from the sandstone formations and amongst non-crustacean taxa generally. In this paper, we compare the pattern of genetic variation with the distribution of morphologically-determined species-level taxa of *Eophreaticus*, with the aim of understanding how speciation has occurred in this species flock.

We present the results of the analysis of two mtDNA markers, 16S rRNA and COI, from 80 individuals, representing 30 presumptive species lineages of *Eophreaticus*, and new data from two related outgroup species in the genus *Eremisopus* Wilson and Keable, 2002b. Material for *Eophreaticus* determinations was acquired from the King, East Alligator and South Alligator River catchments (see Appendix). Our mtDNA evidence indicates the presence of at least 24 independent genetic lineages. We argue that speciation in these distinct lineages of *Eophreaticus* is a consequence of their behaviour, unique habitat requirements and the monsoon-influenced environment of this region, with alteration between high desiccation and high rainfall, both on a yearly and

* Corresponding author.

E-mail addresses: buz.wilson@austmus.gov.au (G.D.F. Wilson), Chris.Humphrey@environment.gov.au (C.L. Humphrey), don.colgan@austmus.gov.au (D.J. Colgan), Kgray90@hotmail.com (K.-A. Gray), Rebecca.Johnson@austmus.gov.au (R.N. Johnson).

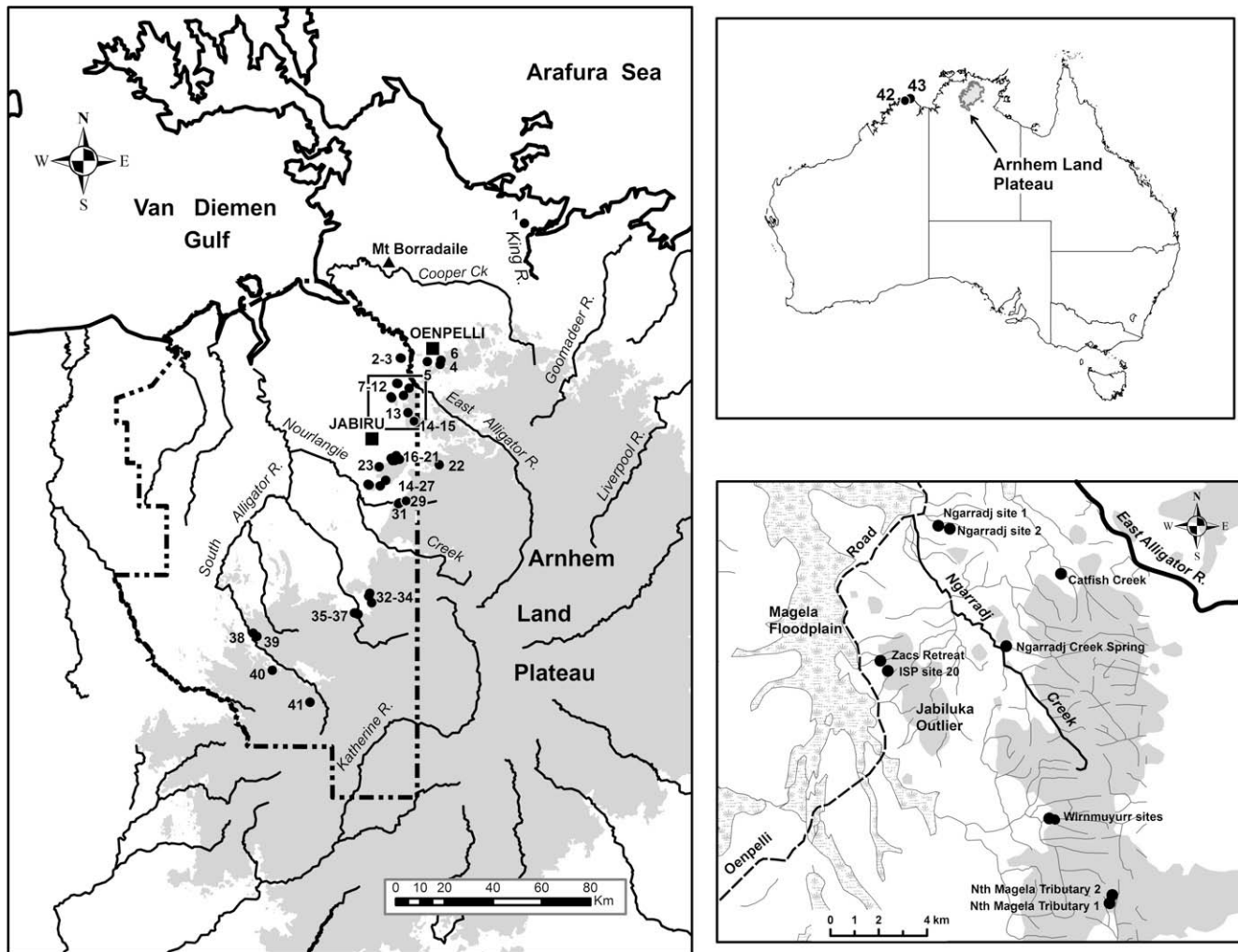

Fig. 1. Map of study area. Upper right, general area within Australia with two *Eremisopus* localities indicated. Left, Arnhem Plateau region showing sample locations; site numbers from which sequences were derived are indicated in the Appendix; not all numbered sites were analysed in this study. The dash-dotted line indicates the current boundaries of Kakadu National Park. Lower right, enlargement of area centred on the Jabiluka Outlier (small square in map on left), which showed the highest density of species.

on a geological time scale. The environment that these isopods occupy, and the results from ongoing studies of invertebrates in Kakadu National Park, are first reviewed to provide a context for understanding these results.

1.1. Environmental setting of the Alligator Rivers region

The study region lies in Australia's wet-dry tropics and has a monsoonal climate, the wet season occurring generally between November and March and the dry season between May and September, with April and October usually transitional months. Annual rainfall at Jabiru Airport over the 36 year period 1971–2007 has averaged 1540 mm (SD = 350 mm). Further inland, however, rainfall decreases, averaging, for example, about 1200 mm per year at one station in the upper South Alligator River. The highly seasonal nature of the rainfall allows flow to occur along the entire length of most streams of the region only from about January to May. Flow ceases over much of the length of the streams during the dry season, persisting only in short upstream sections fed by escarpment springs and seepage. Whilst a majority of sites associated with the main plateau in the Kombolgie sandstone formation of the western Arnhem and Kakadu regions (Sweet et al., 1999) retain surface waters year-round, other sites, particularly those associated with sandstone outliers (sites 1, 5–6, 8–13, Fig 1, Appendix), dry out after wet season

rains and short recessional flow periods. Marked seasonality of rainfall developed in the region in the Late Tertiary (Russell-Smith et al., 1995). The long-term reliability of the seasonal rainfall since that time is not known. Persistence of water, particularly in the least eroded sandstone formations in the north that have scarcely changed since the Miocene (Galloway, 1976), may have been enhanced by high permeability and fragmentation. The resulting expanded catchment surface area and high substrate porosity, as well as elevation of the formations, entraps significant rainwaters that are released throughout the year to underground crevices or surface seeps at or near the base of escarpments. These form the primary habitat for *Eophreatoicus* species.

1.2. Distribution of other species in Kakadu National Park

The high level of endemism of isopods associated with the Kombolgie sandstone formations is consistent with that reported for other groups of biota, including freshwater shrimps (Page et al., 2008) and terrestrial plants (Woinarski et al., 2006). For plants, this region is recognised as a biodiversity 'hotspot' in national and international assessments. The high levels of endemism have been attributed to multiple factors including the highly dissected nature of the formations and their general isolation (impeding gene flow), topographic complexity (providing an array of microhabitats) and

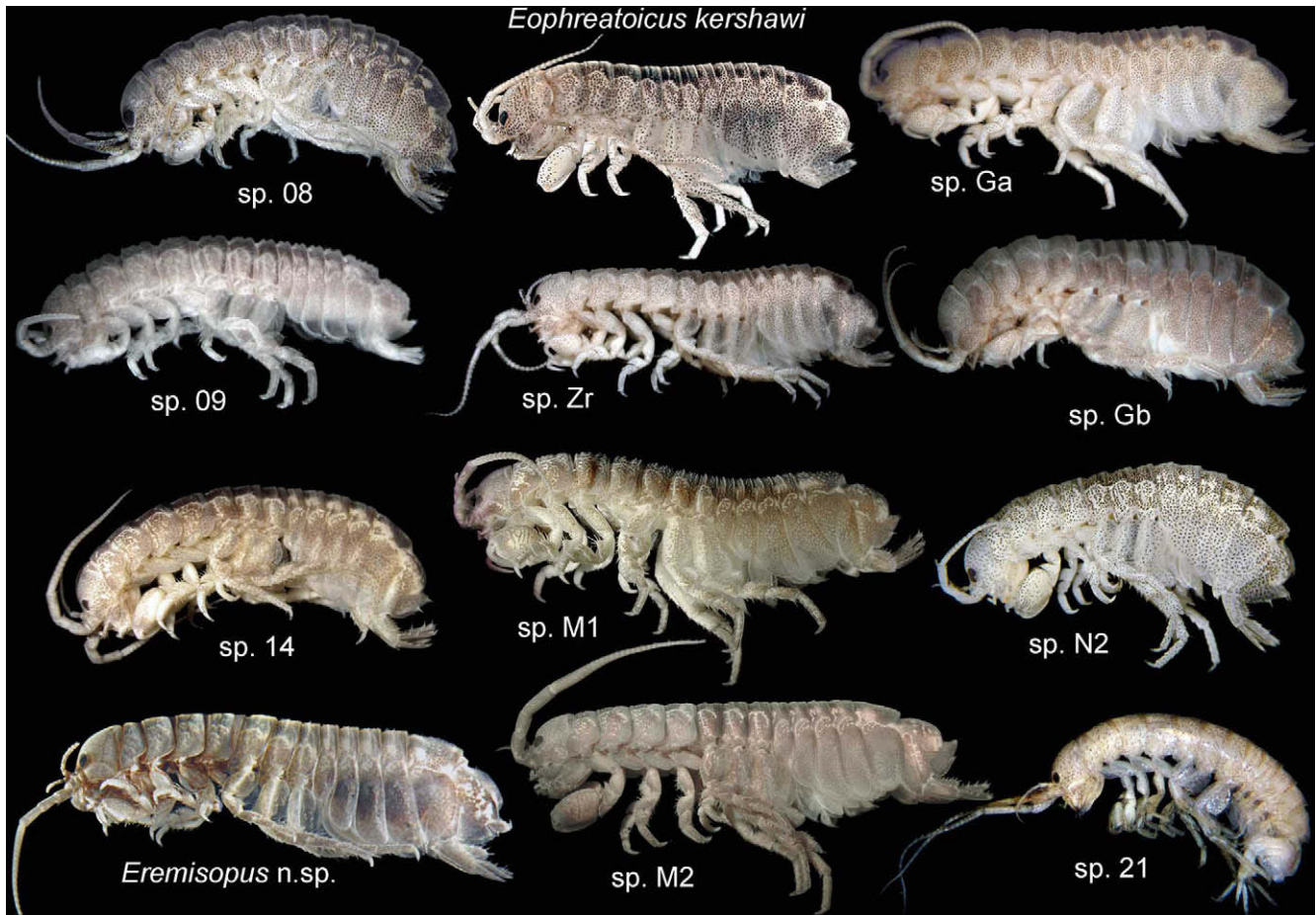

Fig. 2. A selection of 11 taxa of *Eophreatoicus* and 1 species of *Eremisopus*. *Eophreatoicus kershawi* Nicholls, top centre, is the only described species in the genus. Several species co-occur (spp. Ga & Gb, 08 & 09) or nearly so (M1 & M2). Not to same scale, most animals around 1.5 cm long.

protection from fire (Woinarski et al., 2006). Additionally, the antiquity of the Kombolgie sandstone formation (Palaeoproterozoic: Sweet et al., 1999) and its more recent immunity to major climatic and sea level variation may have allowed this landscape to evolve an unique fauna. Associated coastal and riverine alluvial plains of the adjacent lowlands, on the other hand, have seen substantial changes during the Pliocene and Pleistocene (Woodroffe et al., 1987; Shulmeister, 1992; Nanson et al., 1993; Nott and Price, 1999).

Apart from isopods, Finlayson et al. (2006) also noted the high level of endemism found in freshwater shrimps of the western Kombolgie sandstone. The shrimp fauna includes an endemic family, the Kakaducarididae (Bruce, 1993; Bruce and Short, 1993; Page et al., 2008), as well as an undescribed atyid species belonging to a new genus (S. Choy, pers. comm.). Consistent with the hypotheses of Woinarski et al. (2006), an unpublished report (by CLH) also attributed the diversity and endemism of the macro-crustacean species to persistence of surface waters or perched-aquifer sources on the plateau/escarpment, the antiquity of the sandstone formations, fragmentation and other isolating mechanisms, and poor dispersal characteristics of these crustacean groups.

In contrast to the endemic macro-crustaceans of the Arnhem-Kakadu sandstone formations, Humphrey (1999) and Finlayson et al. (2006) observed that the non-crustacean freshwater invertebrate fauna and aquatic insects of Australia's Wet-Dry tropics, lacked similar localised endemism. As a result of these contrasting levels of endemism in different members of the freshwater fauna, our understanding of evolution in the landscape of the Arnhem-Kakadu region requires a knowledge of the biology of each specific group.

1.3. Gene flow potential in *Eophreatoicus* populations

Several factors in the distribution and biology of *Eophreatoicus* species may influence gene flow between populations. The primary mode of locomotion for these isopods is walking and young are brooded, so they have no high-dispersal stage in their life cycle (Wilson, 2008a), unlike the more widely-distributed, local aquatic insect fauna. Copulation and brooding in *Eophreatoicus* species have not yet been observed outside of the dry season, implying that mating occurs in the refugial sites in the sandstone outliers (see Fig. 1) when the populations attain high densities. One of us (CLH, pers. observations) has observed that adult isopods become particularly active after the first rains of the wet season, typically in October and November. For those populations obliged to seek dry season refuge in sub-surface waters, re-wetting and flooding of waterholes and water-courses invariably results in the immediate appearance of large numbers of active adults. Once continuous flow along the streams is met during the wet season, adult and juvenile isopods may disperse downstream of the dry season refugia, although the maximum distance appears to be limited to only a few kilometres (observed for *Eophreatoicus* juveniles, Fig. 3). This limited dispersal may be a source of genetic isolation.

In seasonally-flowing watercourses, mass upstream migrations of adult isopods to dry season refugia occur during the mid to late wet seasons (CLH, personal observations). These observations provide evidence that the downstream dispersing isopods are not simply lost from the breeding populations; they indicate, rather, a highly localised pattern of migration, with limited opportunity for mixing between adjacent populations.

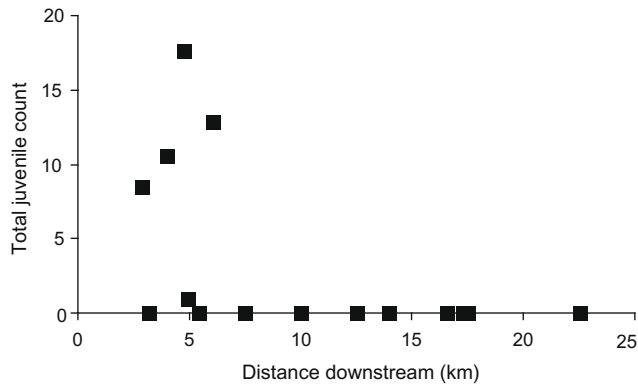

Fig. 3. Total number of juvenile isopods collected along sandy stream channel downstream of refugial areas in Kakadu National Park. Samples were associated with wet season macroinvertebrate sampling, 1998–2003. Distances downstream indicate the distance between the sampling sites and the dry season refugial reaches of the creeks upstream, where the watercourses leave the sandstone plateau and escarpments.

Isopods may be observed and collected in large numbers at all times in populations that are resident year-round in permanent surface waters, particularly those where predatory fish are absent (e.g., Lightning Dreaming Creek, spp. 08 & 09; Appendix and Fig. 1). The generally small size of these surface waters, and their limited flow and isolation during the dry season, however, might restrict gene flow among these year-round populations at these localities.

Over geological time, patterns of dispersal and gene flow might differ. The isopods are efficient climbers over moist substrates and have been observed (by CLH) on the walls of near-vertical crevices and waterfalls. Under particularly wet conditions in the past (Nanson et al., 1993; Nott and Price, 1999), upstream dispersion could have resulted in isopod propagules entering the headwaters of adjacent catchments. Because the propagules were likely to be genetically differentiated from resident populations, sites may have accumulated two or more taxa over time, some of which would be genetically related to those in adjacent catchments.

2. Methods

2.1. Specimens

Eophreaticoicus specimens (see Appendix for sites and accession numbers) were collected by hand from streams and springs using small plastic sieves or by sweep nets. Ethanol-preserved specimens of *Eremisopus* Wilson and Keable, 2002b, the putative sister group (Wilson and Keable, 2002a), and specimens of a new species of *Eremisopus* were also used. All specimens were preserved in either 70% ethanol with 5% glycerine added or in 95% ethanol.

All specimens were assigned to putative species, indicated by alphanumeric 2 digit identifiers, as indicated in the Appendix. These taxa were identified on the basis of a series of morphological features found to vary amongst sites, but to be consistent within sites. An untrained observer should be able to distinguish most species.

Several individuals from each species (see Appendix for exact numbers) and from each locality were chosen for DNA extraction. Each specimen was dissected, providing limb or trunk tissue for DNA extraction; the remaining carcass parts were retained as vouchers. In most cases, the voucher is the carcass of the specimen used for analysis, but in a few instances, the voucher consists of another individual from the same sample. In many cases, these same individuals were used for scanning electron microscopy and scored in a taxonomic database. All species with adequate numbers of

specimens and sufficient character support will be described as part of our ongoing research (Wilson and Humphrey, in progress).

2.2. DNA extractions

Genomic DNA was extracted from tissues stored in ethanol using a CTAB extraction method modified from Saghai-Marooof et al. (1984) or a commercial kit, QIAGEN DNeasy Blood and Tissue Kit (following the Animal Tissue Protocol). Tissues extracted using the DNeasy Kit were washed twice with 200 μ L of Phosphate-Buffered Saline (Sambrook and Russell, 2001) to remove ethanol prior to extraction. Genomic DNA vouchers and tissues were deposited in the Australian Museum DNA Laboratory Tissue Collection, separate from the carcasses deposited in the AM general collections (accession numbers in the Appendix).

2.3. DNA amplification

PCR amplifications, in a total volume of 50 μ L, contained 2 mM MgCl₂, 0.05 mM of each dNTP, 1 \times NH₄ Buffer (Bioline), 0.2 μ M each primer, 0.5 μ L BSA (10 mg/ml) and 1U of Taq DNA polymerase (Bioline). The thermocycling profile used for all primer pairs included an initial denaturing step of 94 $^{\circ}$ C for 5 min, followed by 35 cycles of 1 min at 94 $^{\circ}$ C, 45 s at 43 $^{\circ}$ C, 45 s at 72 $^{\circ}$ C followed by a final extension of 72 $^{\circ}$ C for 5 min.

Part of the mitochondrial 16S rRNA gene was amplified using the 16SF and 16SR (Miya and Nishida, 1996) or 16Sa and 16Sb primer sets (Bybee et al., 2004). The mitochondrial cytochrome c oxidase subunit 1 (COI) region was amplified using the primer pair LCO1490 and HCO2198 from Folmer et al. (1994). In addition, new COI region primers for this study were designed to cover most of the same positions as the Folmer fragment. The new primer sequences were based on the mitochondrial genomes of *Ligia oceanica* (Kilpert and Podsiadlowski, 2006) and *Idotea baltica* (Podsiadlowski and Bartolomaeus, 2006). These primers were ISO-POD F1 (5'-ATT CTA CCA ACC ATA AGG ATA TTG G-3'), and ISOPOD R1 (5'-TCA AAA AAA GAT GTA TTT AAG TTT CG-3'). They amplify a 620 bp fragment.

2.4. DNA sequencing

Sequencing reactions were performed in both directions using DYEnamic ET Dye Terminator (Amersham Biosciences) or ABI Big Dye v3.1 (Applied Biosystems). The post-reaction clean up was done using ammonium acetate and ethanol precipitation, and products were then run on a MegaBACE 500 (Amersham Biosciences). Some sequencing also was done off site at MacroGen Inc. Chromatogram checking, comparison of the two run directions and contig sequence formation were conducted in SEQUENCHER™ 4.7 (GeneCodes Corporation).

2.5. Data assembly

In the initial stages of this project, multiple DNA extracts and sequences were obtained from single isopod individuals to assess the level of experimental variation in the determination of base sequences. Verification of the sequences from some isopod specimens employed repeated extractions and independent PCRs. Two specimens of the outgroup taxon (*Eremisopus* n. sp.) were sequenced, but each specimen provided usable sequence for only one of the two genes, so this terminal in the combined data set is a composite of 16S rRNA from specimen E33 and CO1 from specimen E34. Because the sequences varied considerably in length owing to lack of specification near the primers, the sequence termini were filled where necessary with the ambiguity code, "N". GenBank accession numbers for the resulting sequences are included

in the [Appendix](#). For fixed alignment parsimony and Bayesian analyses, the sequences were aligned using the default parameters in CLUSTALX (Thompson et al., 1997). The sequences were then concatenated in BioEdit (Hall, 1999) for combined analyses. A second data set with both data partitions was created with all single sequence taxa deleted.

2.6. Phylogenetic analysis

2.6.1. Fixed alignment parsimony

Fixed alignment parsimony was performed using PAUP* version 4.0b10 (Swofford, 2001), on the 16S rRNA and COI data sets separately and combined. Gaps were treated as “missing”, and multi-state positions in one taxon were interpreted as “uncertainty”. Starting trees were obtained via random stepwise addition. A tree-space sampling protocol was used, including 10,000 samples of 3 trees (PAUP* commands: *hsearch addseq = random nchuck = 3 chuckscore = 1 nreps = 10,000 randomize = trees; hsearch start = current nchuck = 0 chuckscore = 0*). The resulting set of trees was studied using strict and Adams consensus methods, implemented in PAUP*, to assess variation in phylogenetic hypotheses. To find the most different trees in this data set, the most distant tree from an arbitrary tree (tree 1) was found using PAUP* command *tree dist*, using the symmetric distance tree metric. One of the most distant trees found was then used as the root to find another most distant tree. These two trees were chosen as the trees for comparison. Both jackknife (Farris et al., 1996) and bootstrap (Felsenstein, 1985) support values were obtained for the combined dataset based on 1000 randomised samples of the data (PAUP* settings for each iteration: *hsearch addseq = random nchuck = 10 chuckscore = 1 nreps = 10 randomize = trees*). The jackknife method using 33% characters deleted from each of the 1000 replicates was preferred because it was more conservative. A partition homogeneity test (1000 iterations) was performed to investigate conflict between the 16S and COI data partitions. Bremer support in PAUP* was calculated using a command script generated by MacClade ver.4 (Maddison and Maddison, 2000).

2.6.2. Bayesian analyses

MrModelTest version 2.2 (Nylander, 2004) was used to select a model for the Bayesian analyses. For both COI and 16S rRNA individually and the combined data, the model selected using the Akaike Information Criterion was GTR + I + γ : that is, a general time reversible substitution matrix with 6 rates, an estimated proportion of invariable sites and a discrete approximation to the gamma distribution (four rate categories) to model rate differences between base positions.

The Bayesian analyses were conducted with MrBayes version 3.1.2 (Huelsenbeck and Ronquist, 2001), using default settings unless specified. The values of the free parameters in the model were estimated during the Metropolis Coupled Monte Carlo Markov Chain simulation. For the combined analyses, parameters were estimated separately for the two genes using the “unlink” command. The simulation was run for one million generations, sampling a tree every 100 generations, with four differentially heated chains. Trees were discarded as “burn-in” up to the point in the chain where the log likelihood of subsequent trees was no more than 0.2 percent worse than that of the best tree [aided by visual inspection in Tracer version 1.4 (Rambaut and Drummond, 2004)]. For the 16S rRNA data, the initial 150,000 generations were discarded. For the COI data, 40,000 generations were discarded. In the combined dataset, the first 200,000 generations were discarded. To understand the differences between the different analyses, a majority rule consensus was found for the (majority rule) consensus from all Bayesian runs, including the separate and combined data partitions. These trees were pruned of taxa with miss-

ing sequences; the trees were then condensed to unique trees, and the majority rule consensus calculated.

2.6.3. Direct optimisation

Unaligned 16S rRNA and COI sequences were analysed in combination using POY3 version 3.0.11 (Gladstein and Wheeler, 1997–2002; Wheeler et al., 2006). The sequences from each fragment were input as separate partitions (COI, 16S) to improve the speed of the analysis by dividing the direct optimisation procedure into logical units (Giribet, 2001; Wheeler et al., 2006). The commands used were: “-nooneasis -nodiscrepancies -approxbuild -buildmaxtrees 10 -norandomizeoutgroup -sprmaxtrees 3 -tbrmaxtrees 3 -fitchtrees -holdmaxtrees 30 -staticapprox -buildsperreplicate 5 -gap 4 -slop 1 -checkslop 5 -treefuse -fusemaxtrees 30 -exact -quick”. This analysis used a gap cost of 4, and transition and transversion costs of 1. Lower gap costs (1 or 2) that were tried in initial runs yielded implied alignments in which inferred indels contradicted codon boundaries in the COI sequences, so these costs were not used. Because run times were long, approximately 3 h per replicate, 90 replicates in total of the above protocol were run on 3 different personal computers, saving the trees from each separate run. Individual runs of 3–15 replicates found nearly identical topologies. The 69 resulting trees of differing lengths were combined into an input tree file and a final analysis of all input trees was run using the command set: “-gap 4 -nooneasis -nodiscrepancies -approxbuild -maxtrees 50 -fitchtrees -replicates 2 -norandomizeoutgroup -slop 1 -checkslop 2 -exact -iterativepass -iterativerandom -iterativekeepbetter -maxiterations 10”.

2.6.4. Divergence time analyses

Divergence times were investigated using relaxed clock methods in the BEAST 1.4 package (Drummond and Rambaut, 2007). *A priori* estimates for divergence times were taken from Ketmaier et al. (2003): 1.5 changes/my, and ~80 My for the divergence of *Colubotelson* and *Crenoicus* of Wilson (2008b).

2.7. Comparisons of geographic and genetic distance

Pairwise geographic (Great Circle) distances between sample localities were calculated using locality data for each collection site. Positions of sites lacking global positioning satellite data were estimated using a gazetteer. The GTR model was used to calculate pairwise genetic divergences in PAUP* because this model was selected for the likelihood analyses. Co-occurring taxa were assigned a distance separation of 0.01 km (10 m, approximate size of each sampling area) by default to allow geographic distance to be shown on a logarithmic scale. The two matrices were used for a Cartesian plot in *OpenOffice.org Calc*, with geographic distance as the independent \log_{10} transformed variable. An approximate geographic trend is indicated by a logarithmic linear regression line, while degree of relationship was tested with a Mantel test (Legendre and Legendre, 1998), implemented in a *MatLab* script by D.L. Jones (University of Miami, Florida).

3. Results

3.1. Base composition

16S rRNA and COI were sequenced for most specimens ([Appendix](#)), but a few did not yield data after repeated attempts. The COI fixed alignment ($N = 71$) had 540 total bases, with 230 parsimony-informative. The 16S rRNA fixed alignment ($N = 75$) had 431 total bases, with 200 that were parsimony-informative. The combined dataset ($N = 80$) had 967 total bases (several bases were deleted from the ends of the sequences during the combination), with 474 constant bases, 69 variable bases that were parsimony-

uninformative, and 424 that were parsimony-informative. χ^2 -tests did not reject the null hypothesis of homogeneity of base composition for either COI ($P = 0.932$) or 16S rRNA ($P = 1.000$).

When compared via Blast with the mitochondrial genomes of several other species (Kilpert and Podsiadlowski 2006; Podsiadlowski and Bartolomaeus, 2006), the sequences were typical of isopod mtDNA. The COI sequences of both *Eremisopus* species and all *Eophreaticoicus* species, however, are unlike any other isopod sequences, based on a survey from several sources (Wetzer 2001, 2002, pers. comm.; Gouws et al., 2005; Gouws and Stewart, 2007) because a 6 base deletion (two amino acids) has occurred at positions 448–453 [based on complete sequences from *Ligia* and *Idotea* (Podsiadlowski and Bartolomaeus, 2006; Kilpert and

Podsiadlowski, 2006)]. Although sequence length variation has been observed in the COI gene of other taxa, this deletion is found consistently only in a restricted clade of Phreaticoidea (2 genera), rather than being a feature of a large clade (e.g., Mollusca Pulmonata except the basal Siphonaria; Grande and Tempado, 2004).

3.2. Bayesian analysis

The consensus of the combined dataset reported here was derived from the retained trees from the run with the best final log likelihood, although differences between runs were minimal. The consensus of the consensus trees from individual analyses had

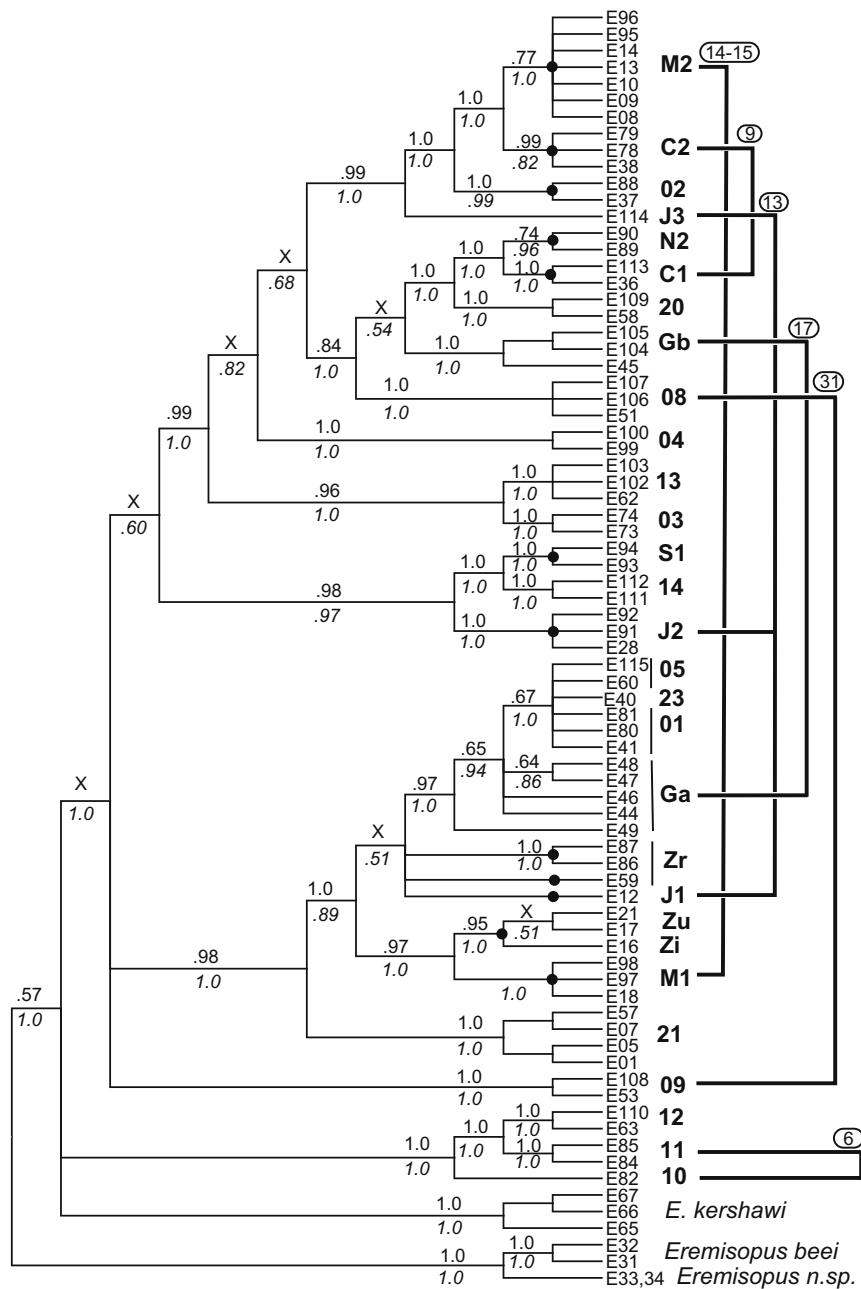

Fig. 4. Analysis of combined fixed alignment data: Bayesian majority rule consensus topology from trees resulting from the run having the best final log likelihood. Numbers above branches are 33% parsimony jackknife support values; "X" indicates Bayesian branches not present in the strict consensus parsimony analysis. Numbers in italics below branches are majority rule frequencies from the Bayesian analysis. Closed circles on branches indicate lineages found in the vicinity of the Jabiluka Outlier. Sites that contain two or more distinct taxa are indicated on right by brackets, with the map number in Fig. 1 shown at upper right corner of each bracket. Vertical lines indicate membership in lineage where the group was not clearly monophyletic.

the same terminal clades as in Fig. 4 (not including taxa with missing sequences). Of those clades that appeared more frequently than 50% in all analyses, most were also found in more than 80% of the trees in the pruned analysis.

3.3. Parsimony analysis

A partition homogeneity test (1000 iterations) using fixed alignment parsimony found that the 16S and COI data partitions have conflicting phylogenetic signals ($P = 0.025$). In comparing the separate partition analyses, most of the disagreement was in the basal parts of the tree. Parsimony analysis of the individual partitions 16S and COI found differing basal relationships for *Eremisopus* spp., *E. kershawi* and *E. spp.* 04 and 09, although this may be an effect of the missing COI sequences for *Eremisopus beei*. In the combined analyses, the missing data had only a small effect on the analyses owing to the independent agreement between terminal clades implied by the 16S rRNA and COI sequences (Table 1). Analyses of reduced data matrices that omitted the species with missing data produced similar results as the complete dataset (not shown).

Owing to the similarity of within-population sequences and missing sequences for one or the other data partition of some species, the combined dataset parsimony analysis of the fixed alignment data set found 1.2×10^6 trees, the analysis being terminated at this number, from which the strict consensus was drawn (resolved clades indicated in Fig. 4). A set of trees from a second analysis with 1000 iterations but without a treespace expansion step obtained a consensus that was identical to the first consensus (tree length = 2052, consistency index (excluding uninformative characters) = 0.3725, retention index = 0.8029, rescaled consistency index = 0.3185). The consensus of two most different trees (Fig. 5) was also identical. The jackknife support analysis

had an effective deletion percentage of 32.9%, or 319 characters removed in each replicate. Most nodes in the strict consensus of the parsimony trees were well supported (above 90%: Fig. 4). Weakly supported nodes occurred in distal clades, such as the spp. 01-05-23-Ga group, or basal nodes. An Adams consensus indicated that the placement of the spp. 10, 11, 12 (from near Oenpelli – now called “Gunbalanya”) in Arnhem Land, map no. 4–5 in Fig. 1) and sp. 09 (from Lightning Dreaming; map no. 31 in Fig. 1) clades varied between several branches, which collapsed the basal consensus. In all cases, *Eophreatoicus kershawi* was basal to the remainder of the *Eophreatoicus* species and *Eremisopus* species were basal to *Eophreatoicus*.

3.4. Direct optimisation

The dynamic homology analysis using POY3 with direct optimisation found 18 trees, length 2411, all topologically similar, but with different implied alignments. Tree 1 (Fig. 6) with branch lengths from its implied alignment shows many of the same clades seen in the other analyses. In tree 18, specimen E16 (species Zi) had an alternative position as sister to the Ga-01-05-23 clade. Notably, these two positions would cause a collapse of 6 branches in a strict consensus of trees from this analysis. The 16S rRNA sequence of this specimen was somewhat shorter than others, and its COI sequence was missing. All other analyses (Bayesian, parsimony, and separate analyses for 16S rRNA alone) placed this terminal in the spp. Zi–Zu clade. The dynamic homology analysis may be more sensitive to missing data because the available data partition (16S rRNA) for specimen E16 was small and therefore poorly constrained. Because the other analyses used a fixed alignment at the outset, differing implied homologies in the 16S rRNA data partition were not an issue.

Table 1

Eophreatoicus species hypotheses and support values from combined analysis of 16S rRNA and COI data. Number of specimens in each group (N), with “Adjacent taxa” indicating monophyletic groups found to be sister to a node basal to the species. Jackknife and Bayesian majority rule clade frequency values are presented as proportions of 1. Direct optimisation results are presented as binary value, monophyly (“1”). Nonmonophyly indicated as “X” throughout. For those taxa with only one representative, the support values (shown parenthetically) are derived from the basal branch where the sister group is supported, too.

Presumed Species (basal node)	N	Adjacent taxa	Bremer support (fixed align.)	Jackknife (fixed align.)	Direct Optimisation (monophyly)	Bayesian posterior probability
<i>E. kershawi</i>	3		33	1	1	1
01	3		X	X	X	X
05	2		X	X	X	X
23	1		X	X	X	X
01,05,23	6		1	0.67	1	1
Ga	5	01,05,23	(2,1)	(0.97,0.67)	X	(0.94,1)
02	2		7	1	1	0.99
03	2		22	1	1	1
04	2		61	1	1	1
08	3		28	1	1	1
09	2		40	1	1	1
10	1	11,12	(13,22)	(1,1)	?	(1,1)
11	2		13	1	1	1
12	2		14	1	1	1
13	3		19	1	1	1
14	2		8	1	1	1
20	2		6	1	1	1
21	4		9	1	1	1
C1	2		6	1	1	1
C2	3		2	0.99	1	0.82
Gb	3		1	1	1	1
J1	1	Uncertain	(8,–)	(1,–)	?	(0.51,–)
J2	3		38	1	1	1
J3	1	02	(8,13)	(0.99,1)	1	(1,1)
M1	3		3	0.99	1	1
M2	7		1	0.77	1	1
X2	2		1	0.74	1	0.96
S1	2		8	1	1	1
Zi	2		X	X	X	X

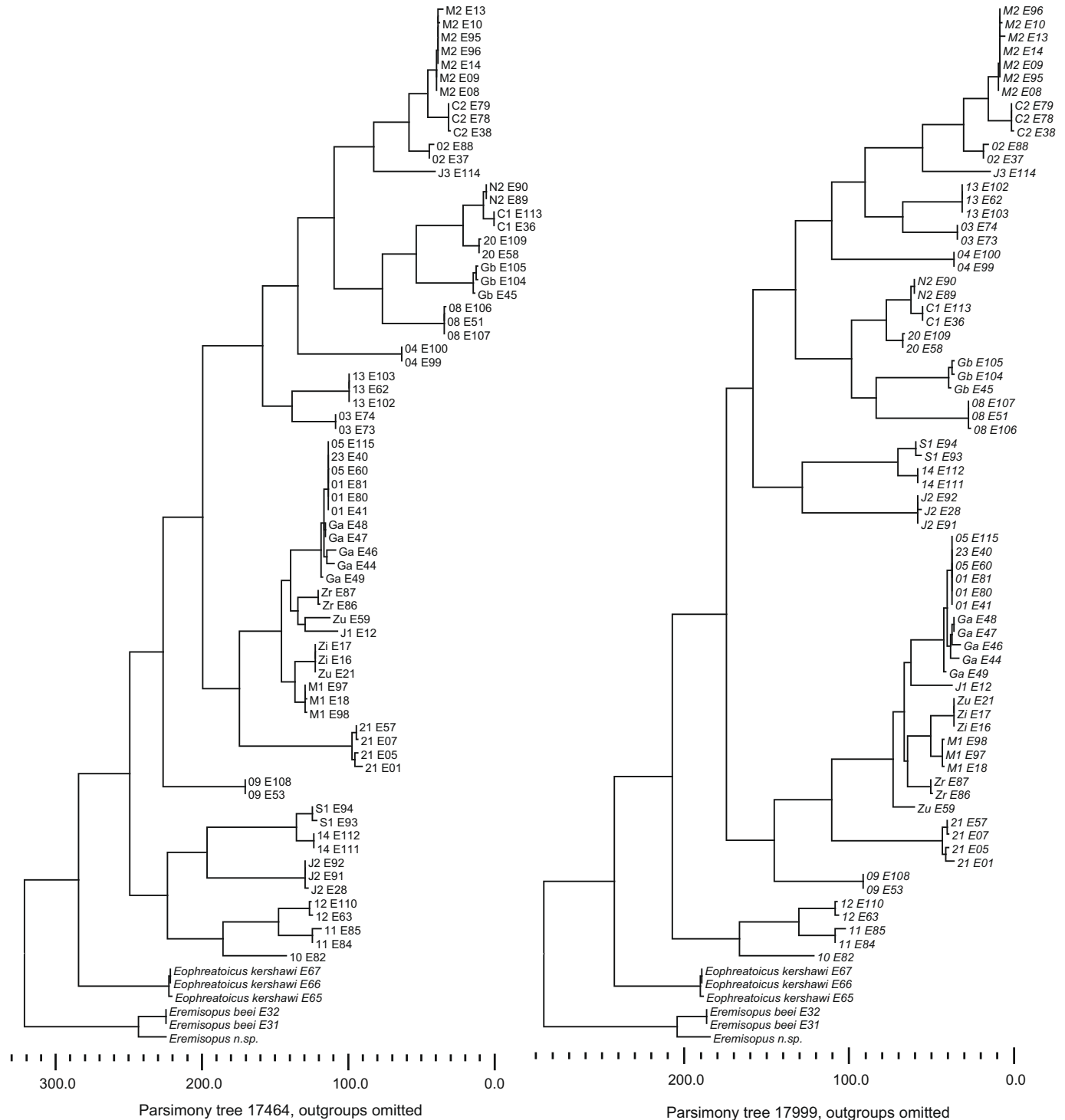

Fig. 5. The two most different trees from set of 1.2×10^6 trees, parsimony analysis of both data partitions. Outgroups with long branch lengths omitted. Scale at bottom indicates changes per branch.

3.5. Monophyletic groups

The *Eremisopus*–*Eophreatoicus* clade is well supported in the parsimony analysis (jackknife = 0.96, not shown in Fig. 4) and the 6 base (2 amino acid) deletion in the cytochrome *c* oxidase subunit I sequences strongly supports the clade. This deletion is a useful synapomorphy of the *Eremisopus*–*Eophreatoicus* clade, relative to the rest of the Phreatoicoidea. Whether selective processes influenced this deletion is uncertain, but it occurs in no other isopod

COI sequence available in GenBank. The *Eophreatoicus* radiation of species is monophyletic based on our combined 16S rRNA and COI phylogenetic estimates. Although the jackknife values were small (0.57 in Fig. 4), the Bayesian posterior probability for that node was high ($P = 1.0$).

Most of the morphologically-determined taxa, except for clades (01, 23, 05, Ga) and Zi, Zu) were strongly supported by the mtDNA evidence (Table 1), regardless of analytical method (Table 1). Species 01 and 05, which are distinctly different morphologically

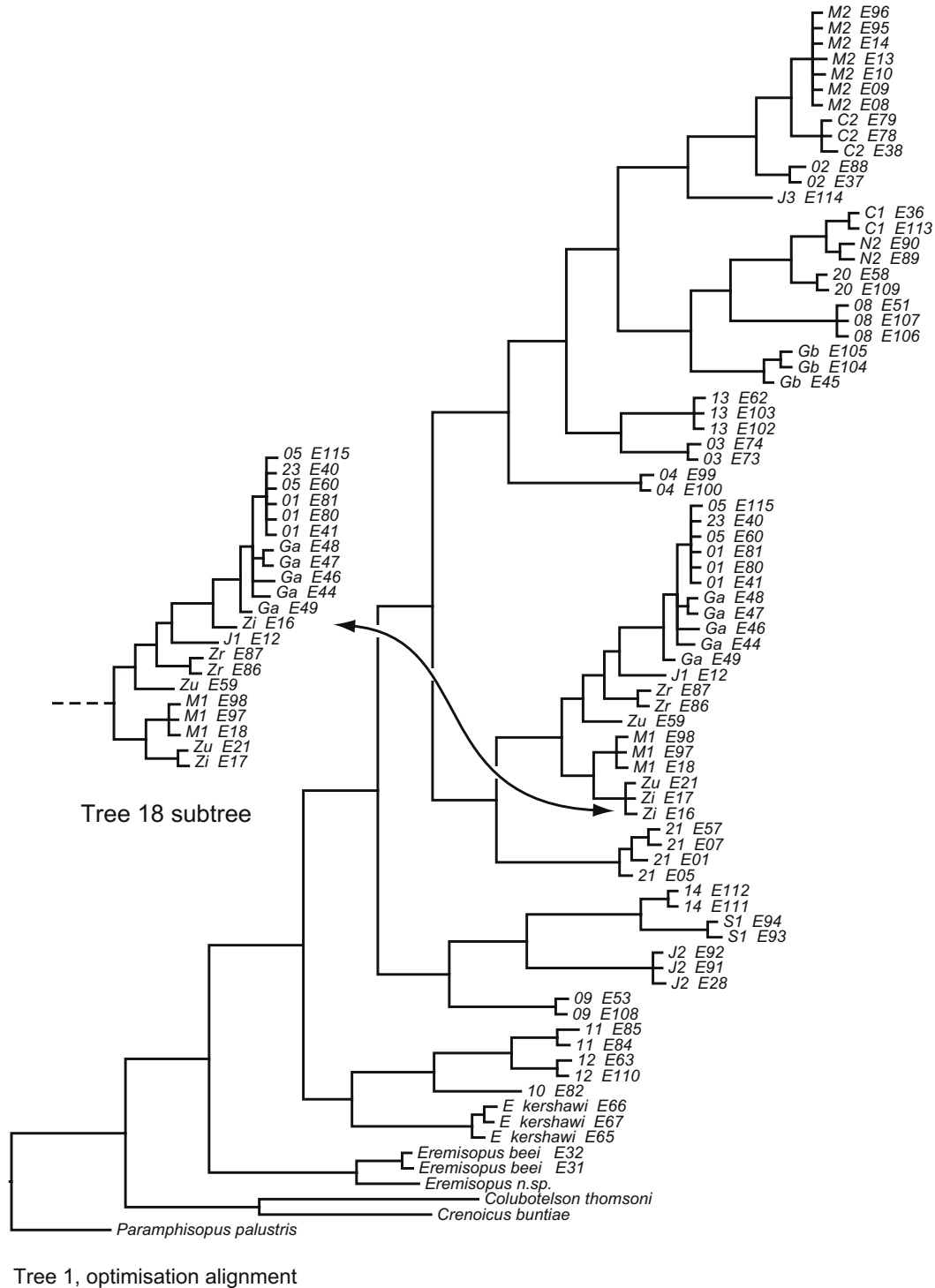

Fig. 6. Direct optimisation analysis of unaligned combined data partitions: topology of 18 trees resulting from a POY (version 3) analysis, with inset of one tree showing alternative placement of one taxon (*E. sp. Zi*, specimen E16). Branch lengths are proportional to changes on the branches derived from implied fixed alignments associated with tree 1.

(Fig. 7), are geographically separated by 16–33 km but have identical mtDNA sequences for both markers. Experimental error or cross-contamination can be ruled out because multiple individuals from each taxon were tested at different times and showed the same sequences. The characters (several shown in Fig. 7), which were used to consistently separate *Eophreatoicus* species, demonstrate that the taxa 01 and 05 are easily distinct.

Previously-identified terminals represented by only one exemplar (spp. 23, 10, J1 and J3) are not resolved as monophyletic by this

analysis. Some are the sister group in the cladograms to other well-supported taxa. Where the clade formed by a pair of sister groups is well-supported, monophyly of the single exemplar can be inferred by exclusion from the other terminals. This inference employs the observation that within-species variation is minimal in those taxa with more than one exemplar, so we assume that the few taxa with only one exemplar will have similar variation. Two of the terminals (spp. 10 and J3) can be assumed to be monophyletic by this reasoning. One singleton terminal (sp. J1) is a member of a larger clade

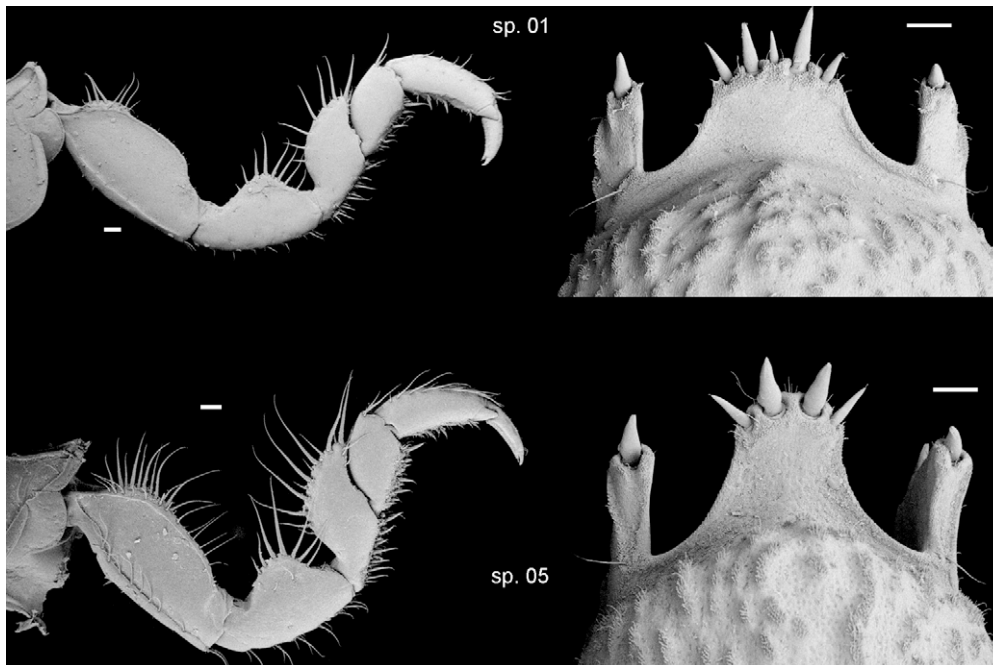

Fig. 7. Scanning electron micrographs: comparison of morphologically distinct (but genetically identical) males from sp. 01 (top) and sp. 05 (bottom). Shown are specimens E81 (sp.01, AM P.76443) and E115 (sp.05, AM P.74578), from which 16S and COI data were obtained (see Appendix). Left, second walking leg in lateral view; note differences in setation on proximal segments. Right, terminal segment of the body (pleotelson) in dorsal view, posterior tip up; note differences in the tip shapes, the tip setae and cuticular ridges on dorsal surface. Scale bar 200 μ .

(spp. 01, 05, 23, Ga, Zr and Zu) that has unresolved relationships, so its monophyly is not established by these analyses.

3.6. Divergence times

An ultrametric tree with branch lengths for the *Eophreatoicus* lineages was adjusted using several anchor points. The relaxed clock analyses, using a lognormal variance distribution, found variable ages for divergence times of the *Eophreatoicus* clades. Although the BEAST analyses with different priors on the basal divergence times repeatedly recovered the same topologies seen in the phylogeny estimation methods, the 95% confidence limits on the times of internal nodes were too high to distinguish between possible alternative dates. In all trees with root priors ranging from 22 My to 100 My, most distal lineages had ages exceeding 1 My. With the root set to 100 My, the *Colubotelson*–*Crenoicus* split became 84 My, near the presumed age of this clade in Wilson (2008b). The ancestral node age of *Eophreatoicus* and *Eremisopus* was 65 My. The tree was also adjusted to a middle Miocene (12 My) time scale for the ancestral node of *Eophreatoicus* and *Eremisopus* to match the aridification of Australia (Crisp and Cook 2007). This changed the estimated date of the root node to nearly 22 My. This experimental adjustment places ages on most lineages that exceed 1.0 My, with many lineages exceeding 2 My. Exceptions were the closely related lineages: C2 and M2; N2, C1 and 20; Ga, 01 and 05 complex.

3.7. Geographic and genetic distances

The comparison between corrected genetic distances and \log_{10} -transformed geographic distances (Fig. 8) showed a wide scatter of points, but with a significant trend. As expected from the low vagility of phreatoicid species, the outgroups showed a direct relationship between distance and genetic distance (as shown by the approximate trend line). The range of divergences within *Eophreatoicus* species, particularly between the more distant species-pairs like *E. kershawi* and sp.03, overlaps with divergences between the

more distant outgroups and *Eophreatoicus*. The pairwise distances (Fig. 8) reveal significant geographic structure in these data (Mantel test $r = 0.495$, $p < 0.001$). No highly divergent taxa (at the genetic divergence levels of the outgroups) co-occurred with *Eophreatoicus* (upper left corner of Fig. 8). The sister genus *Eremisopus* is intermediate in distances (~ 700 km). Similarly, *Eophreatoicus* species are confined to the Northern Territory (no points in the lower right corner of Fig. 8), with the most geographically and genetically distant being *E. kershawi* at the 150 km scale. The outgroups and *Eophreatoicus* show an approximate geographic trend (by logarithmic regression) that intercepts the horizontal axis below the 100 m scale (dashed line), the observed scale of sites. Within *Eophreatoicus*, genetic distances seem to reach a plateau around 25%, clustering tightly at the 10–100 km scale.

Genetically unrelated taxa co-occur, and some closely related sister clades occur in the 1–20 km range. Morphologically distinct taxa that co-occurred had genetic distances ranging from 0.2545 to 0.0940; these include species pairs 08–09, 10–11, C1–C2 and Ga–Gb and the Jabiluka triplet J1–J2–J3 (Fig. 4, brackets on right side). This results in many points lying on the left axis of Fig. 8 at divergences mostly above 20%, and with few between 1 and 20%. Species M1 and M2 occurred separately but only 300 m apart in the same headwater tributary of North Magela Creek. We did not have sufficient specimens for analysis of other co-occurring pair members of species S1 and N2 (also genetically separate), so the number of distinct lineages represented by our data should be regarded as a minimum.

4. Discussion

4.1. Approximate ages of the lineages

We have found nearly 30 distinct species, making *Eophreatoicus* the most speciose genus in the suborder Phreatoicidea. The high genetic diversity found in the mitochondrial clades of *Eophreatoi-*

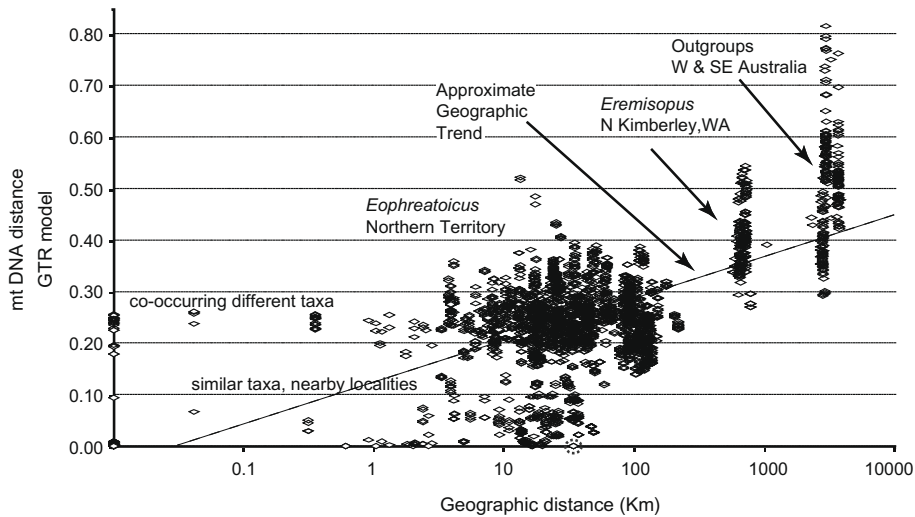

Fig. 8. Pairwise comparison of geographic (great circle distances in km, logarithmic scale) and genetic distances (in percent divergence, model GTR). Co-occurring taxa are assigned to a geographic distance of 0.01 km (10 m) by default. A logarithmic regression of all points is indicated by a dotted line ($y = 0.04 \log(x) + 0.12$; $R^2 = 0.42$). Dotted circle on x axis indicates value for spp. 01 and 05.

cus, together with substantial geographic structuring, is evidence for a long period of divergence in the Kakadu–Arnhem Plateau region. Although our exploration of divergence times using different root ages for rate estimation analysis was inconclusive, the general result was that most lineages appear to be over 1 million years old. Certainly, the lineages deep in the tree, such as the split between *Eophreaticoicus* and *Eremisopus*, are older than 15 million years when the aridification of Australian habitats became more intense (Frakes, 1999; Crisp and Cook, 2007). The development of the Australian monsoon, with marked rainfall seasonality in northern Australia in the late Miocene/early Pliocene (Russell-Smith et al., 1995) may have been a factor in the diversification seen in this group, as discussed below. The origin of *Eophreaticoicus* + *Eremisopus* clade could possibly be ancient, perhaps more than 100 My, because it is well separated from other members of the family, both genetically and morphologically (cladogram in Wilson and Edgecombe, 2003). Closely related genera in another freshwater isopod family, the Hypsimetopidae, are known to have ages based on geophysical data of more than 130 My (Wilson, 2008b), so an age of this magnitude is not out of the question.

4.2. Haplotype variation within and between populations

Conspecific populations show little nucleotide variation in mtDNA haplotypes. We suspect that the tight clustering of individuals during the dry season, when the females are inseminated, may increase the potential for the pruning of mitochondrial lineages during genetic bottlenecks (e.g., Hoelzel, 1999; Weber et al., 2000). If the populations were subjected to a period of extreme aridity, as presumed during recent glacial-interglacial cycles (Nanson et al., 1993), their sizes may have been so reduced that the fixation or near fixation of mitochondrial genotypes occurred readily. A lack of nucleotide variability in many of the populations may also be caused by selective sweep (Amos and Harwood, 1998) where selection favours one mitochondrial variant over another. Although we have no direct evidence for this process, selection associated with maternally-transferred endosymbionts (cf. Hurst and Jiggins, 2005) may be one possibility.

A pattern of reciprocal monophyly between demes is not unexpected, if the effective dispersal is low. Theoretical models (Irwin, 2002) demonstrate that a continuously distributed metapopulation can develop significant geographical structure when the rela-

tive population size is small and dispersal potential is low. The extreme isolation of isopod populations for part of the year in small pools or subterranean refuges, combined with their ability to return to home springs, must be a significant factor in the fixation of mitochondrial haplotypes, regardless of whether a selective sweep was active in these populations.

4.3. Problems for genetic barcodes

Two morphologically distinct lineages, sp. 01 and sp. 05 (Fig. 7), have identical mtDNA haplotypes, at least based on the 16S and COI data. We assume that their distinctiveness is also reflected in the nuclear genome, although we currently lack supportive nDNA evidence. These taxa are geographically proximate (16–30 km) but at the margin of the geographic range of genetically similar taxa (Fig. 8, dotted circle on x-axis). These lineages may have overlapped geographically sometime in the past, during which time a brief period of hybridisation took place. Subsequently, the mtDNA haplotype might have become fixed as it has in most of the lineages, without re-establishment of gene flow or significant introgression between the lineages. Whatever the cause, mtDNA markers for identification of these isopods must be used with caution.

4.4. Homing behaviour in *Eophreaticoicus* species

The mtDNA data allow inferences on behaviour and speciation in *Eophreaticoicus*. The distinctiveness of each population is evidence that they have highly limited gene flow between nearby localities. As described above, *Eophreaticoicus* species may enter the streams during the monsoonal wet season and have been observed swimming, walking or climbing upstream later in the wet season, and so by inference are assumed to return to specific refugia for the dry season. Because isopods of differing genotypes, at least in theory, could come into contact in the streams during the wet season, the expectation is that genetic mixing should be much higher than observed. Observations of other, non-crustacean invertebrate species in these waters (Finlayson et al., 2006) support this expectation. For the isopods to maintain conservative genotypes with substantial geographic structure, they must have high fidelity to particular spring locations. As discussed above, the wet season is a significant period of recruitment and dispersion of *Eophreaticoicus* species. The downstream limit of occurrence

of juveniles, however, is no more than 2–6 km from their dry season refuges in the upper reaches of the creeks (Fig. 3). Thus, a downstream limit to isopod movement may prevent their dispersion to other streams in the region wherever streams become confluent at distances greater than several kilometres from the headwater refuges.

The data from one taxon, species Ga, provide additional evidence that homing behaviour in these isopods may limit their gene flow. Species Ga came from several different sites in Gulung Creek (Fig. 1 map no.16–21) that were separated at most by 2.4 km, showing pairwise genetic divergences ranging from 0.23% to 1.19%. Because each population lives in dense, low-dispersal clusters alternating with periods of potential mixing in Gulung Creek, we can explain these results as a strong preference for individuals to return to home springs, thus resulting in low genetically-effective dispersal.

4.5. Geographic structure

Did the *Eophreatoicus* species flock arise *in situ* in the Kakadu and Arnhem Plateau region? The significant geographic structure in their genetic relationships (Fig. 8) supports this case: more divergent taxa are more distant geographically. The dense clustering of genetic distances at the 5–120 km range suggests that speciation tends to occur allopatrically at these scales. The lineages that differ genetically by less than 10% are probably explained by relatively recent dispersal and subsequent divergence.

The geographic distribution of genetic divergences showed that distinct genotypes are limited to small geographic areas at scales of 0.1–1 km distance. These small scales and the natural history of these isopods suggest that the genetically effective ambit of an *Eophreatoicus* deme (that is, the geographic scale at which gene flow takes place) may be constrained by their homing behaviour and limited available habitat during the dry season. Although the geographic distances used in this analysis are direct lines between sites, the actual distances separating related populations in different watersheds may be greater owing to the aquatic landscape in which they live. For example, sp. C2 (Catfish Creek, Fig. 1 map no. 9) and sp. M2 (north tributary of Magela Creek, Fig. 1 map no. 14), which are distinct lineages separated by only a small genetic distance (2–3%, uncorrected), are found in different catchments (East Alligator River and Magela Creek respectively) that eventually drain to the East Alligator River. While the direct distance between the sites is only 13.4 km, distance by stream connectivity is over 100 km. These two taxa (sp. C2 and sp. M2) are the sister group of the taxon O2 (with genetic distances to this taxon of 4–5% and 3–4% respectively), which is found in the upper Magela Creek (33.7 km and 20.7 km by direct distance, or approximately 110 and 50 km by stream connectivity, respectively). The habitats of taxa N2 and C1, also similar morphologically and genetically (~1% divergence), are separated by 4.8 km direct distance. Both readily identifiable taxa, however, are living in watersheds that are separated by ~75 km via stream connectivity. Resolution of the species status of these similar taxa will be addressed in a combined analysis of the morphological and molecular data, which will then further inform the scale in which speciation takes place in this group.

Possibly the most morphologically contrasting species pair that have identical haplotypes (illustrated in Fig. 7), sp. 01 (Nanguluwur; Fig. 1 map no. 25–26) and sp. 05 (Blue Tongue Dreaming; Fig. 1 map no. 19), occur a small direct distance apart (16–30 km for the various sites). Considerable in-stream connectivity distance, however, separates their ranges in the South and East Alligator River catchments, respectively. In past glacial periods of lower sea lev-

els when the two river systems presumably became confluent in lower freshwater reaches (now inundated by the Van Diemen Gulf, Fig. 1), the connectivity distance between the sites would have been approximately 230 km!

4.6. Patterns of speciation

Isopod population dispersion may have been either greater or lesser during the past glacial–interglacial cycles, especially during periods of widespread flooding and inundation (Shulmeister, 1992; Nott and Price, 1999) or extreme aridity (Frakes, 1999; Chappell, 1983) when sea levels may have been substantially lower than now. This extreme temporal variation in climate both on a monsoonal annual scale (Russell-Smith et al., 1995) and on a geological scale (Shulmeister, 1992; Nott and Price, 1999) would have influenced the geographic patterns of speciation in the genus. We infer two processes from assumed shifts in the yearly monsoonal cycle that may explain the observed patterns in species of *Eophreatoicus*.

1. Extreme aridity during the glacial periods may have reduced population sizes considerably, so that localised deme extinctions and genetic bottlenecks were more frequent. The isolation at small geographic scales would have increased the probability of localised extinction as well as decreasing the possibility of any inter-deme gene flow. These population contractions might explain low intrapopulation genetic variability, as well as explaining the divergence between the major lineages. Populations bottlenecks may limit genetic diversity (Hoelzel, 1999), and reduced population sizes may also enhance the effectiveness of active selective processes in the genome (Amos and Harwood, 1998). Similarly, extinctions caused by earlier cycles of extreme aridity would have eliminated some ancestral populations entirely resulting in a loss of potentially intermediate forms and an increase in average genetic distances between remaining populations.
2. Conversely, the wetter glacial (Nott and Price, 1999) or interglacial periods may have allowed propagules from distinct lineages to colonise habitats far from their home range, which would explain co-occurrences of genetically distinct lineages. The success of occasional founder populations could have led to the co-habitation of distinct lineages at the same sites, especially those around the Jabiluka Outlier. Included in this expanded colonisation, the wetter periods may also have facilitated *upstream* migration of isopods into adjacent catchments (see discussion above related to the climbing abilities of *Eophreatoicus*) – as evidenced by numerous occurrences of genetically similar species in catchments separated by short direct distances but relatively long stream connectivity distances. Subsequent differentiation of isolated propagules would add considerably to the multiplication of the species.

We suspect that the probability of speciation most likely followed a gradient over the western Arnhem Plateau from a high in the northwest portion of the sandstone formations to a low in the south coinciding with greater dissectedness, height and stability of the plateau and higher rainfall in the northwest. We found the highest number of distinct lineages in an area around the Jabiluka Outlier (Fig. 1; lower right inset) where highly dissected sandstone ridges and outliers with a myriad of associated small streams are particularly evident. These lineages are indicated on Fig. 4 by a dot on the branch. Although species-level categories have not yet been assigned to these taxa, this area contains 5–6 species at a conservative minimum, and 12 genetically distinct lineages (Table 1).

4.7. Endemism in *Eophreaticoicus*

Our study finds that the mitochondrial genomes of species in the genus *Eophreaticoicus* show significant geographic structuring, with many sites in the region of investigation possibly hosting up to two or more distinctive taxa. The lack of geographic dispersion of each species, often with limitations to single upper catchments means that *Eophreaticoicus* species are narrow range endemics, which has important implications for their conservation. Although our evaluation of the underlying sources for their diversity and endemism is incomplete, our evidence argues for the presence of unique behavioural restrictions to gene flow coupled with a highly varying monsoonal climate as major factors. Unsourced or poorly sampled localities around the Arnhem Plateau are likely to contain more taxa of this diverse genus, raising the possibility that any human-caused changes to localised aquatic habitats will negatively impact currently unknown unique species and populations. Clearly, the continuation of Kakadu and Arnhem Land as protected areas of high conservation value is essential for the continued existence of its known and yet-to-be-discovered high diversity of freshwater crustacean taxa.

Acknowledgments

We are especially grateful for the support of the Australian Biological Resources Survey Grant, 204-59 as well as additional funding from the Supervising Scientist Division of Australia's Department of Environment, Water, Heritage and Arts. The following individuals assisted in providing specimens that were essential for this project: W. Ponder, A. Storey, A. Cameron, K. McAlpine, K. Brennan, L. Thurtell, D. Elphick, L. Chandler, A. Sullivan, M. Daniel, P. Dostine, G. Spiers and other rangers of Kakadu National Park (*Parks Australia*). The traditional owners of the various districts of Kakadu National Park as well as Arnhem Land granted access to their land for sampling. We are grateful for the assistance of K. Hall, D. O'Meally, D. Sharkey & J. Studdert, who participated in the lab effort, and A. Cerra S. and Lindsay, who assisted with the SEM imaging. We thank Gary Fox and Renee Bartolo from ERIS for providing and modifying the map, and two anonymous referees for helpful suggestions to improve the paper.

Appendix A

Specimens, sites, vouchers and accession numbers. Locality positions, if available, in decimal degrees of South latitude and East longitude. Map numbers are shown in Fig. 1. (* indicates that vouchers are different from the specimen sequenced. All sequences except those specified in the last three rows of the Table were collected for this study.

Presumed Species	Extract. ID #	AM acc. # (voucher)	Collection Location Geocodes in decimal degrees	Map no.	GenBank COI Acc.#	16S rRNA Acc. #
<i>E. kershawi</i>	E65	P.74570	Sandstone Outlier N and W of King River Estuary (presumed type locality), Arnhem Land, NT -11.876917° 133.39490°	1	EU263136	EU263206
<i>E. kershawi</i>	E66	P.74571			EU263137	EU263208
<i>E. kershawi</i>	E67	P.74572			EU263138	EU263207
23	E40	P.76449	Nourlangie Rock Cave, Kakadu N.P.	26	EU263167	EU263238
01	E41	P.76440	Nanguluwur (west side of Nourlangie Rock), Kakadu N.P. -12.842333° 132.81717°	25	EU263139	—
01	E80	P.76442			EU263140	EU263210
01	E81	P.76443	Cave stream, Nawurlandja,(Little Nourlangie Rock), Kakadu N.P.	26	EU263141	EU263209
02	E37	P.74596	Upper Magela Creek, Kakadu N.P., -12.77° 133.08°	22	EU263142	EU263211
02	E88	P.74597			EU263143	EU263212
04	E100	P.76454	Seep to left of Twin Falls, Kakadu N.P., -13.3215° 132.78083°	37	EU263147	EU263216
04	E99	P.76453			EU263146	EU263215
05	E115	P.74578	E side Blue Tongue Dreaming, Mt. Brockman, Kakadu N.P., -12.75° 132.93333°	19	EU263185	EU263257
05	E60	P.74577			—	EU263217
08	E106	P.72642	Lightning Dreaming, Kakadu N.P., -12.912667° 132.92967°	31	EU263149	EU263219
09	E108	P.72625			EU263152	EU263222
08	E107	P.72641	Lightning Dreaming Creek (3028), in main pool below waterfall (#3), Kakadu N.P., -12.912667° 132.92967°	31	EU263150	EU263220
08	E51	P.74580			EU263148	EU263218
09	E53	P.74586	Lightning Dreaming Creek, pools below main pool (#4), Kakadu N.P., -12.912667° 132.92967°	31	EU263151	EU263221
10	E82	P.76306	Escarpment stream south of Gunbalanya (Oenpelli), Arnhem Land, NT, -12.383333° 133.08667°	6	EU263153	EU263223
11	E84	P.76311			EU263154	EU263224
11	E85	P.76312			EU263155	EU263225
12	E110	P.76315	Gorge running east-west from Gunbalanya Road (Oenpelli Rd.), Arnhem Land, NT, -12.388333° 133.03667°	5	EU263157	EU263227
12	E63	P.76317			EU263156	EU263226
13	E102	P.76284	Spring in side branch of Dinner Creek NT245, Kakadu N.P., -13.646667° 132.60333°	41	EU263159	EU263229
13	E103	P.76285			EU263160	EU263230

(continued on next page)

Appendix A. (continued)

Presumed Species	Extract. ID #	AM acc. # (voucher)	Collection Location	Geocodes in decimal degrees	Map no.	GenBank COI Acc.#	16S rRNA Acc. #
13	E62	P.76282				EU263158	EU263228
14	E111	P.76320	Cannon Hill/Hawk Dreaming, Stockyard Creek, Kakadu N.P., -12.375056° 132.93672°		2	—	EU263231
14	E112	P.76321				—	EU263232
20	E109	P.72628	Creek north of Namarrkon Gorge, Kakadu N.P., -12.902778° 132.95583°		29	EU263162	EU263234
20	E58	P.74573				EU263161	EU263233
21	E01	P.74563	Leichhardt Springs, Kakadu N.P., -12.7775° 132.85833°		23	EU263163	EU263235
21	E05	P.74568*				EU263164	EU263236
21	E57	P.72638				EU263166	EU263237
3?	E73	P.76288	Jackpot Creek, OSS site 4, Kakadu N.P., -13.391333° 132.3935°		38	EU263144	EU263213
3?	E74	P.53197	Dogleg Creek, Kakadu N.P., -13.403167° 132.40717°		39	EU263145	EU263214
C1	E113	P.76369	Catfish Creek CH1205, Kakadu N.P., -12.486667° 132.96900°		9	EU263169	EU263240
C1	E36	P.76372				EU263168	EU263239
C2	E38	P.76374				—	EU263241
C2	E78	P.76376				EU263170	EU263242
C2	E79	P.76377				EU263171	EU263243
Ga	E44	P.76266	Gulungul site 1, first south tributary in Radon Springs, Kakadu N.P., -12.754667° 132.90833°		21	EU263172	EU263244
Ga	E46	P.76268	Gulungul site 2, seep upstream in Radon Springs, Kakadu N.P., -12.754333° 132.91667°		20	EU263173	EU263245
Ga	E47	P.76270	Gulungul site 3, pools in north tributary of Radon Springs, Kakadu N.P., -12.745333° 132.92433°		17	EU263174	EU263246
Ga	E48	P.76276	Gulungul site 4, small seep in north tributary of Radon Springs, Kakadu N.P., -12.736500° 132.92167°		16	EU263175	EU263247
Ga	E49	P.76272	Gulungul site 5, eastern tributary of Gulungul Creek, Kakadu N.P., -12.746167° 132.9025°		18	EU263176	EU263248
Gb	E45	P.74600	Gulungul site 1, first south tributary in Radon Springs, Kakadu N.P., -12.754667° 132.90833°		21	EU263177	EU263251
Gb	E104	P.74603	Gulungul site 3, pools in north tributary of Radon Springs, Kakadu N.P., -12.745333° 132.92433°		17	EU263178	EU263249
Gb	E105	P.74604				EU263179	EU263250
J1	E12	P.76325	Wirnmuyurr Creek site (7-J) 2 + 500 m, Kakadu N.P., -12.577806° 132.96675°		13	EU263180	EU263252
J2	E28	P.76365	Wirnmuyurr Creek Scree (7-J) (near Jabiluka), Kakadu N.P., -12.578083° 132.96688°		13	EU263181	EU263253
J2	E91	P.76362				EU263182	EU263254
J2	E92	P.76363				EU263183	EU263255
J3	E114	P.74593				EU263184	EU263256
M1	E18	P.76384	N Magela Tributary site 1, Kakadu N.P., -12.608997° 132.987°		15	EU263186	—
M1	E97	P.76388				EU263187	EU263258
M1	E98	P.76389				EU263188	EU263259
M2	E08	P.76391*	N Magela Tributary site 2, Kakadu N.P., -12.605997° 132.98800°		14	EU263189	EU263260
M2	E09	P.76391*				EU263189	EU263260
M2	E10	P.76392				EU263190	EU263265
M2	E13	P.76393				EU263191	EU263263
M2	E14	P.76394				—	EU263261
M2	E95	P.76396				EU263192	EU263264
M2	E96	P.76397				EU263193	EU263262
N2	E89	P.76381	Ngarradj site 2, ERISS stn A00846, Kakadu N.P., -12.469933° 132.92775°		8	EU263194	EU263266
N2	E90	P.76382				EU263195	EU263267
S1	E93	P.76355	Ngarradj Creek Spring, AC CH, Kakadu N.P., -12.513567° 132.94867°		10	EU263196	EU263268
S1	E94	P.76356				EU263197	EU263269
Zi	E16	P.76292	West flowing tributary of Jabiluka Outlier, Kakadu N.P., -12.522722° 132.90481°		12	—	EU263272
Zi	E17	P.76293				EU263200	EU263273
Zr	E86	P.76298	site ZR (Zac's Retreat), Kakadu N.P., -12.519° 132.902028°		11	EU263198	EU263270
Zr	E87	P.76299				EU263199	EU263271

Appendix A. (continued)

Presumed Species	Extract ID #	AM acc. # (voucher)	Collection Location	Geocodes in decimal degrees	Map no.	GenBank COI Acc.#	16S rRNA Acc. #
Zu	E21	P.76301*	West flowing tributary of Jabiluka	Outlier March 2003, Kakadu N.P.		EU263201	–
Zu	E59	P.76303				EU263202	EU263274
<i>Eremisopus beei</i>	E31	P.76477	South Creek, N. of Honeymoon Bay, Kalumbaru, WA,	-14.175783° 126.68982°	42	–	EU263204
	E32	P.76478				–	EU263205
<i>Eremisopus n.sp.</i>	E33	P.76480	Faraway Bay Creek, from a small (1 - 2 m wide), spring-fed creek,	A. Storey & S. McIntosh, Northern Kimberleys, WA, -13.9825° 127.18833°	43	–	EU263135
	E34	P.76481				EU263203	–
<i>Paramphisopus palustris</i>	publ.	P.44487*	COI: Gouws and Stewart (2007); 16S: Wetzer (2001, 2002)		–	EF203030	AF259533.1
<i>Colubotelson thomsoni</i>	publ.	P.64427*	Wetzer (2001, 2002)		–	AF255775.1	AF259531
<i>Crenoicus buntiae</i>	publ.	P.45340*	Wetzer (2001, 2002)		–	AF255776	AF260870

References

- Amos, W., Harwood, J., 1998. Factors affecting levels of genetic diversity in natural populations. *Phil. Trans. R. Soc. Lond. B* 353, 177–186.
- Bruce, A.J., 1993. *Kakaducaris glabra* gen. nov., sp. nov., a new freshwater shrimp from the Kakadu National Park, Northern Territory, Australia, Crustacea, Decapoda, Palaemonidae with the designation of a new subfamily Kakaducaridinae. *Hydrobiologia* 268, 27–44.
- Bruce, A.J., Short, J.W., 1993. *Leptopalaemon gagadjui* gen. nov., sp. nov., a new freshwater palaemonid shrimp from Arnhem Land, and a re-evaluation of *Palaemonetes holthuisi* Strenth, with the designation of a new genus, *Calathaemon*. *Hydrobiologia* 257, 73–94.
- Bybee, S.M., Taylor, S.D., Nelson, C.R., Whiting, M.F., 2004. A phylogeny of robber flies (Diptera: Asilidae) at the subfamilial level: molecular evidence. *Mol. Phylogenet. Evol.* 30, 789–797.
- Chappell, J., 1983. A revised sea-level record for the past 300,000 years from Papua New Guinea. *Search* 14, 99–101.
- Crisp, M.D., Cook, L.G., 2007. A congruent molecular signature of vicariance across multiple plant lineages. *Mol. Phylogenet. Evol.* 43, 1106–1117.
- Drummond, A.J., Rambaut, A., 2007. BEAST: Bayesian evolutionary analysis by sampling trees. *BMC Evol. Biol.* 7, paper 214.
- Farris, J.S., Albert, V.A., Källersjö, M., Lipscomb, D., Kluge, A.G., 1996. Parsimony jackknifing outperforms neighbor-joining. *Cladistics* 12, 99–124.
- Felsenstein, J., 1985. Confidence limits on phylogenies: an approach using the bootstrap. *Evolution* 39, 783–791.
- Finlayson, C.M., Lowry, J., Bellio, M.G., Nou, S., Pidgeon, R., Walden, D., Humphrey, C., Fox, G., 2006. Biodiversity of the wetlands of the Kakadu Region, northern Australia. *Aquatic Sci.* 68, 374–399.
- Folmer, O.M., Black, M., Hoeh, R., Lutz, R., Vrijenhoek, R., 1994. DNA primers for amplification of mitochondrial cytochrome c oxidase subunit I from diverse metazoan invertebrates. *Mol. Mar. Biotech.* 3, 294–299.
- Frakes, L.A., 1999. Evolution of Australian environments. In: Orchard, A.E. (Ed.), *Flora of Australia*, Second ed. ABR/CSIRO, Canberra, vol. 1, pp. 163–203.
- Galloway, R.W., 1976. Geology of the Alligator Rivers area. In: Story, R., Galloway, R.W., McAlpine, J.R., Aldrick, J.M., Williams, M.A.B.J. (Eds.), *Lands of the Alligator Rivers Area*, Northern Territory, CSIRO, Melbourne, Land Research Series No. 38, pp. 52–70.
- Giribet, G., 2001. Exploring the behavior of POY, a program for direct optimization of molecular data. *Cladistics* 17, S60–S70.
- Gladstein, D.S., Wheeler, W.C., 1997–2002. POY: The Optimization of Alignment Characters. American Museum of Natural History, New York, NY. Documentation by D. Janies and W.C. Wheeler.
- Gouws, G., Stewart, B., 2007. From genetic structure to wetland conservation: a freshwater isopod *Paramphisopus palustris* (Phreatoicoidea: Amphisiopidae) from the Swan Coastal Plain, Western Australia. *Hydrobiologia* 589, 249–263.
- Gouws, G., Stewart, B.A., Matthee, C.A., 2005. Lack of taxonomic differentiation in an apparently widespread freshwater isopod morphotype (Phreatoicoidea: Mesamphisopidae: *Mesamphisopus*) from South Africa. *Mol. Phylogenet. Evol.* 37, 289–305.
- Grande, C., Templado, J., 2004. Molecular phylogeny of Euthyneura (Mollusca: Gastropoda). *Mol. Biol. Evol.* 21, 303–313.
- Hall, T.A., 1999. BioEdit: a user-friendly biological sequence alignment editor and analysis program for Windows 95/98/NT. *Nucl. Acids. Symp. Ser.* 41, 95–98.
- Hoelzel, A.R., 1999. Impact of population bottlenecks on genetic variation and the importance of life-history; a case study of the northern elephant seal. *Biol. J. Linn. Soc.* 68, 23–39.
- Huelsenbeck, J.P., Ronquist, F.R., 2001. MRBAYES: Bayesian inference of phylogeny. *Bioinformatics* 7, 754–755.
- Humphrey, C.L., 1999. Potential effects of the Jabiluka Mine upon the biodiversity of Kakadu National Park. In: Response to the ICSU Review of the Supervising Scientist's Report to the World Heritage Committee. Supervising Scientist, Environment Australia, Darwin, Australia, Appendix 3.
- Hurst, G.D.D., Jiggins, F.M., 2005. Problems with mitochondrial DNA as a marker in population, phylogeographic and phylogenetic studies: the effects of inherited symbionts. *Proc. Roy. Soc. Lond. Series B* 272, 1525–1534.
- Irwin, D.E., 2002. Phylogeographic breaks without geographic barriers to gene flow. *Evolution* 56, 2383–2394.
- Ketmaier, V., Argano, R., Caccione, A., 2003. Phylogeography and molecular rates of subterranean aquatic stenassellid isopods with a peri-Tyrrhenian distribution. *Mol. Ecol.* 12, 547–555.
- Kilpert, F., Podsiadlowski, L., 2006. The complete mitochondrial genome of the common sea slater, *Ligia oceanica* (Crustacea, Isopoda) bears a novel gene order and unusual control regions features. *BMC Genomics* 7, 241.
- Legendre, P., Legendre, L., 1998. *Numerical Ecology*. Elsevier Science BV, Amsterdam.
- Maddison, W.P., Maddison, D.R., 2000. *MacClade 4.0, Analysis of Phylogeny and Character Evolution*. Sinauer Associates, Inc. Sunderland, Massachusetts, USA.
- Miya, M., Nishida, M., 1996. Molecular phylogenetic perspective on the evolution of the deep-sea fish genus *Cyclothone* (Stomiiformes: Gonostomidae). *Ichthyol. Res.* 43, 375–398.
- Nanson, G.C., East, T.J., Roberts, R.G., 1993. Quaternary stratigraphy, geochronology and evolution of the Magela Creek catchment in the monsoon tropics of northern Australia. *Sediment. Geol.* 83, 277–302.
- Nicholls, G.E., 1926. A description of two genera and species of Phreatoicoidea, with a discussion of the affinities of the members of this family. *J. Roy. Soc. W. Australia* 12, 179–210 (pls.125–128).
- Nott, J.F., Price, D.M., 1999. Waterfalls, floods and climate change: evidence from tropical Australia. *Earth Planet. Sci. Lett.* 171, 267–276.
- Nylander, J.A.A., 2004. MrModeltest, version 2. Program distributed by the author, Evolutionary Biology Centre, Uppsala University.
- Page, T.J., Short, J.W., Humphrey, C.L., Hillyer, M.J., Hughes, J.M., 2008. Molecular systematics of the Kakaducarididae (Crustacea: Decapoda: Caridea). *Mol. Phylogenet. Evol.* 46, 1003–1014.
- Podsiadlowski, L., Bartolomeus, T., 2006. Major rearrangements characterize the mitochondrial genome of the isopod *Idotea baltica* (Crustacea: Peracardina). *Mol. Phylogenet. Evol.* 40, 893–899.
- Rambaut, A., Drummond, A.J., 2004. Tracer 1.3. Available from: <<http://beast.bio.ed.ac.uk/Tracer>>.
- Russell-Smith, J., Needham, S., Brock, J., 1995. The physical environment. In: Press, T., Lea, D., Webb, A., Graham, A. (Eds.), *Kakadu – Natural and Cultural Heritage and Management*. Australian Nature Conservation Agency and the Northern Australian Research Unit, The Australian National University, Darwin, pp. 94–126.
- Saghai-Maroo, M.A., Soliman, K.M., Jorgensen, R.A., Allard, R.W., 1984. Ribosomal DNA spacer length and variation in barley: Mendelian inheritance, chromosomal location and population dynamics. *Proc. Natl. Acad. Sci. USA* 81, 8018–8021.
- Sambrook, J., Russell, D., 2001. *Molecular Cloning: a Laboratory Manual*, third ed. Cold Spring Harbor Laboratory. Press, Cold Spring Harbor, New York.

- Shulmeister, J., 1992. A Holocene pollen record from lowland tropical Australia. *The Holocene* 2, 107–116.
- Sweet, I.P., Brakel, A.T., Carson, L., 1999. The Kombolgie Subgroup – a new look at an old 'formation'. *AGSO Res. Newslett.* 30, 26–28.
- Swofford, D.L., 2001. PAUP*: Phylogenetic Analysis Using Parsimony (* and other methods), Version 4b10. Sinauer Associates, Sunderland, Massachusetts.
- Thompson, J.D., Gibson, T.J., Plewniak, F., Jeanmougin, F., Higgins, D.G., 1997. The CLUSTAL X windows interface. flexible strategies for multiple sequence alignment aided by quality analysis tools. *Nucl. Acids Res.* 25, 4876–4882.
- Weber, D.S., Stewart, B.S., Garza, J.C., Lehman, N., 2000. An empirical genetic assessment of the severity of the northern elephant seal population bottleneck. *Curr. Biol.* 10, 1287–1290.
- Wetzer, R., 2001. Hierarchical analysis of mtDNA variation and the use of mtDNA for isopod (Crustacea: Peracarida: Isopoda) systematics. *Contr. Zool.* 70, 23–39.
- Wetzer, R., 2002. Mitochondrial genes and isopod phylogeny (Peracarida: Isopoda). *J. Crustac. Biol.* 22, 1–14.
- Wheeler, W.C., Aagesen, L., Arango, C.P., Faivovich, J., Grant, T., D'Haese, C., Janies, D., Smith, W.L., Varón, A., Giribet, G., 2006. Dynamic Homology and Phylogenetic Systematics: A Unified Approach Using POY. American Museum of Natural History, New York.
- Wilson, G.D.F., 2008a. Global diversity of isopod crustaceans (Crustacea; Isopoda) in freshwater. *Hydrobiologia* 595, 231–240.
- Wilson, G.D.F., 2008b. Gondwanan groundwater: subterranean connections of Australian phreatoicidan isopods (Crustacea) to India and New Zealand. *Invert. Systematics* 22, 301–310.
- Wilson, G.D.F., Edgecombe, G.D., 2003. The Triassic isopod *Protamphisopus wianamattensis* (Chilton) and comparison with extant taxa (Crustacea, Phreatoicidea). *J. Paleontol.* 77, 454–470.
- Wilson, G.D.F., Keable, S.J., 2002a. New Phreatoicidea (Crustacea: Isopoda) from Grampians National Park, with revisions of *Synamphisopus* and *Phreatoicopsis*. *Mem. Mus. Vic.* 59, 457–529.
- Wilson, G.D.F., Keable, S.J., 2002b. New genera of Phreatoicidea (Crustacea: Isopoda) from Western Australia. *Rec. Aust. Mus.* 54, 41–70.
- Woinarski, J.C.Z., Hempel, C., Cowie, I., Brennan, K., Kerrigan, R., Leach, G., Russell-Smith, J., 2006. Distributional pattern of plant species endemic to the Northern Territory, Australia. *Aust. J. Bot.* 54, 627–640.
- Woodroffe, C.D., Chappell, J.M., Thom, B.G., Wallensky, E.P., 1987. Depositional model of a macro-tidal estuary and floodplain, South Alligator River, Northern Australia. *Sedimentology* 36, 737–756.